

Mod. **PRH**

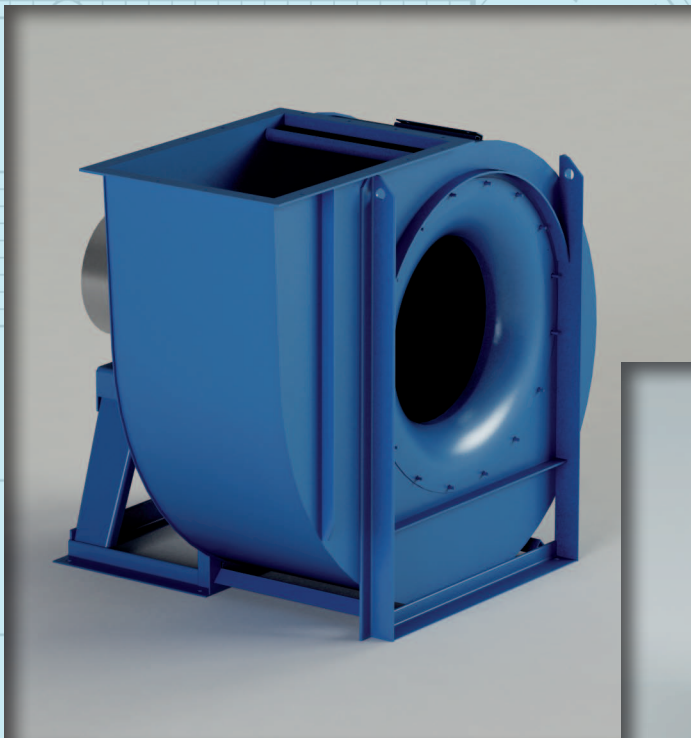

$Q = 1800 \div 288000 \text{ m}^3/\text{h}$

$Q = 0.5 \div 80 \text{ m}^3/\text{s}$

$p_t = 60 \div 530 \text{ mmH}_2\text{O}$

$p_t = 600 \div 5200 \text{ Pa}$



PRH
Campo di lavoro

Portate medie-alte. Pressioni medie.

Tipo di pala

Curva, rovescia (negativa), vedi pag. 2.2.

Applicazioni

Per aspirazione e trasporto di aria pulita o polverosa.

Esecuzioni costruttive standard

Es.1-Es.4-Es.5-Es.8-Es.9-Es.12, vedi pag. 2.5 - 2.6.

Temperature del fluido standard

-10÷+60°C. Per altre temperature vedi da pag. 1.12 a pag. 1.15.

Tipo di costruzione

Ventilatore in lamiera di Fe360, girante in Fe360 equilibrata staticamente e dinamicamente.

Per altri materiali vedi da pag. 1.12 a pag. 1.15.

Dati di funzionamento

 Condizioni dell'aria all'aspirazione T=20°C, 0m.s.l.m. e ρ=1.205 kg/m³.

Rumorosità

 Espresa in potenza sonora L_{wA} [dB(A)] rilevata in campo libero con ventilatore canalizzato, vedi da pag. 1.43 a pag. 1.49.

Orientamenti

N°8 RD (rotazione oraria vista lato trasmissione) e N°8 LG.

Ventilatore in versione imbullonata orientabile per le taglie 400-630, orientamento fisso per le taglie 710-2000. Vedi pag. 2.7.

Costruzioni speciali

Vedi da pag. 2.20 a pag. 2.30.

Classi giranti

La seguente tabella fa riferimento a condizioni di lavoro standard.

In condizioni di esercizio gravose si consiglia di contattare il servizio clienti di CORAL per conoscere la tipologia di girante più idonea.

GRANDEZZA VENTILATORE • Grandeur • Size • Größe • Tamaño	RPM MASSIMO • Maxi tours/min. • Max rpm • Max. U/min • R.p.m. máx.			
	CLASSE I	CLASSE II	CLASSE III	CLASSE IV
PRH400	3450	3900	4500	
PRH450/R	3150	3600	4250	
PRH450	3050	3500	4000	
PRH500/R	2900	3300	3850	
PRH500	2750	3150	3700	
PRH560/R	2550	2900	3550	
PRH560	2450	2800	3400	
PRH630/R	2300	2600	3200	
PRH630	2200	2500	3000	
PRH710/R	2350	2800	3100	3550
PRH710	2200	2650	2950	3350
PRH800/R	2050	2500	2750	3150
PRH800	1950	2350	2600	2950
PRH900/R	1800	2200	2400	2750
PRH900	1750	2050	2250	2550
PRH1000/R	1600	1950	2100	
PRH1000	1550	1850	2000	
PRH1120/R	1700	1850	2000	
PRH1120	1600	1750	1900	
PRH1250/R	1500	1650	1800	
PRH1250	1400	1550	1700	
PRH1400/R	1300	1450	1600	
PRH1400	1200	1350	1500	
PRH1600	1000	1150	1300	
PRH1800	850	1000	1150	
PRH2000	750	900	1050	

VALORI VALIDI FINO A 60°C

 • Valeurs valables jusqu'à 60°C • Values valid up to 60°C
 • Werte bis 60°C gültig • Valores válidos hasta 60°C

FRA • entre • between • zwischen • entre	E • et • and • und • y	DECLASSARE VELOCITÀ • déclasser vitesse • degrade speed • Geschwindigkeit herabsetzen • rebajar velocidad	60°C	100°C	4%
			100°C	150°C	10%
150°C	200°C	16%			
200°C	250°C	23%			
250°C	300°C	30%			
300°C	350°C	37%			
350°C	400°C	45%			
400°C	450°C	54%			
450°C	500°C	64%			

■ Domaine de travail

Débits moyens-élevés. Moyennes pressions.

Type d'ailette

Courbée, inversée (négative), voir page 2.2.

Applications

Pour aspiration et transport d'air propre ou poussiéreux.

Configurations de constructions standard

Ex.1- Ex.4- Ex.5- Ex.8- Ex.9- Ex.12, voir pages 2.5 - 2.6.

Températures du fluide standard

-10÷+60°C. Pour d'autres températures voir pages 1.12-1.15.

Type de fabrication

Ventilateur en tôle de Fe360, turbine en Fe360 équilibrée statiquement et dynamiquement. Pour d'autres matériaux, voir pages 1.12-1.15.

Données de fonctionnement

 Conditions de l'air à l'aspiration T=20°C, 0 m asl et ρ=1.205 kg/m³.

Niveau sonore

 Exprimé en puissance sonore L_{wA} [dB(A)], relevé à l'air libre avec un ventilateur canalisé, voir pages 1.43 - 1.49.

Orientations

8 RD (rotation dans le sens des aiguilles d'une montre côté transmission) et 8 LG. Ventilateur en version boulonnée orientable pour les tailles 400-630, orientation fixe pour les tailles 710-2000. Voir page 2.7.

Fabrications spéciales

Voir pages 2.20-2.30.

Classes de turbines

Le tableau ci-dessus fait référence aux conditions de travail normales, en conditions de travail pénibles, on préconise de contacter le service clientèle de CORAL pour connaître le type de turbine le plus adapté.

■ Field of operation

Medium-high flow rates. Average pressures.

Blade type

Curve, backward (negative), see pg. 2.2.

Applications

For the inlet and transport of clean or dusty air.

Standard constructional arrangements

Arr.1-Arr.4-Arr.5-Arr.8-Arr.9-Arr.12, see pgs. 2.5 - 2.6.

Standard fluid temperatures

-10÷+60°C. For other temperatures see pgs. 1.12 to 1.15.

Type of construction

Fan in Fe360 plate, impeller in Fe360 statically and dynamically balanced. For other materials see pgs. 1.12 to 1.15.

Operating specifications

 Condition of inlet air T=20°C, 0 m above sea level and ρ=1.205 kg/m³.

Noise level

 Expressed as sound power L_{wA} [dB(A)] measured in free field with ducted fan, see pgs. 1.43 to 1.49.

Orientations

No.8 RD (clockwise viewed from transmission side) and No.8 LG. Fan in bolted orientable version for sizes 400-630, fixed orientation for sizes 710-2000. See pg. 2.7.

Special applications

See pgs. 2.20 to 2.30.

Impeller classes

The above table refers to standard operating conditions, in heavy-duty service conditions it is advisable to contact the CORAL Customer Service to establish the most suitable type of impeller.

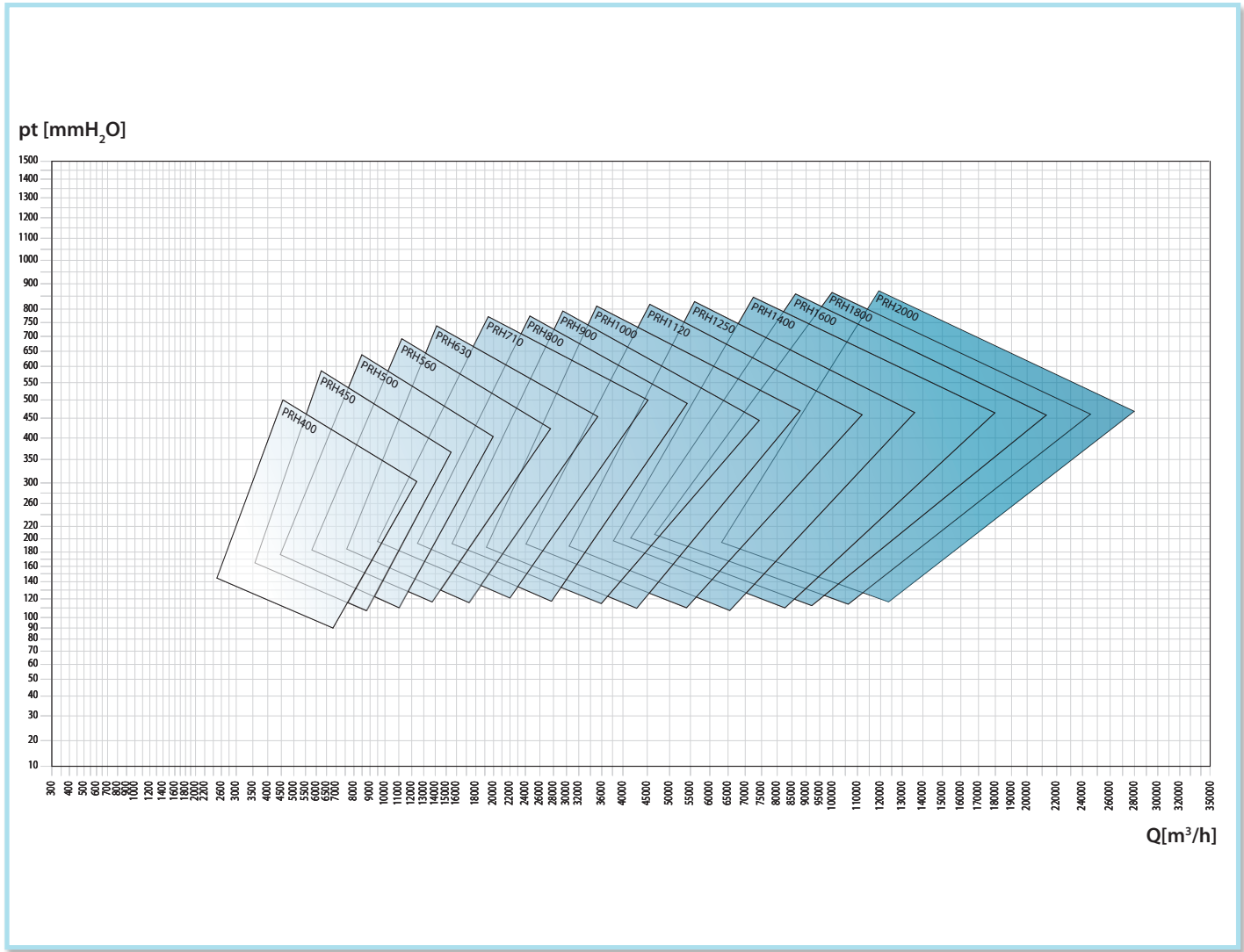

■ **Arbeitsbereich**

Mittlere - grosse Fördermengen. Mittlere Drücke.

Schaufelform

Kurve, rückwärts gekrümmt (negativ), siehe Seite 2.2.

Anwendungen

Zur Absaugung und zum Transport von sauberer und staubhaltiger Luft.

Konstruktive Standardausführungen

Ausf. 1-Ausf. 4-Ausf. 5-Ausf. 8-Ausf. 9-Ausf. 12, siehe Seiten 2.5 - 2.6.

Standardtemperatur des Mediums

-10 ÷ +60°C. Für andere Temperaturen siehe Seiten 1.12 bis 1.15.

Konstruktionsart

Ventilator aus Blech Fe360, Laufrad aus Fe360, statisch und dynamisch ausgewuchtet. Für andere Materialien siehe Seiten 1.12 bis 1.15.

Betriebsdaten

Physikalischer Zustand der Ansaugluft T = 20°C, 0 m ü. M. und ρ = 1.205 kg/m³.

Geräuschpegel

angegeben als Schalleistungspegel L_{WA} [dB(A)] mit Messung im Freifeld und an Rohren angeschlossenem Ventilatore, siehe Seiten 1.43 bis 1.49.

Ausrichtung

8 Modelle RD (Drehrichtung im Uhrzeigersinn, von Antriebsseite aus gesehen) und 8 Modelle LG. Angeschraubter, in der Ausrichtung veränderbarer Ventilator in den Grössen 400 - 630, mit Vorderstütze und damit nicht veränderbar ab Grösse 710 mit Riementrieb, immer ausrichtbar bei allen direkt angetriebenen Ventilatoren ohne Vorderstütze, siehe Seite 2.7.

Spezialausführungen

Siehe Seiten 2.20 bis 2.30.

Laufradklassen

Die obenstehende Tabelle bezieht sich auf normale Betriebsbedingungen. Bei erschwerenden Betriebsbedingungen wird empfohlen, den Kundenservice von CORAL zu kontaktieren, um den am besten geeigneten Laufradtyp zu bestimmen.

■ **Campo de trabajo**

Caudales medios-altos. Presiones medias.

Tipo de pala

Curva, invertida (negativa), ver pág. 2.2.

Aplicaciones

Para aspiración y transporte de aire limpio o cargado de polvo, incluso con pequeñas cantidades de serrín, virutas de distintos tipos y materiales granulados, exceptuando los materiales filamentosos.

Variantes constructivas estándares

Ejec. 1-Ejec. 4-Ejec. 5-Ejec. 8-Ejec. 9-Ejec. 12, ver págs. 2.5 - 2.6.

Temperaturas del fluido estándares

De -10 a +60°C. Para otras temperaturas, ver págs. de 1.12 a 1.15.

Tipo de construcción

Ventilador de chapa en Fe360, rotor en Fe360 equilibrado estática y dinámicamente. Para otros materiales, ver págs. de 1.12 a 1.15.

Datos de funcionamiento

Condiciones del aire en aspiración T=20°C, 0 m SNM y ρ=1.205 kg/m³.

Niveles de ruido

Expresados en potencia sonora L_{WA} [dB(A)] medida en campo abierto con ventilador canalizado, ver págs. de 1.43 a 1.49.

Orientaciones

8 RD (rotación dextrógira vista desde el lado de transmisión) y 8 LG. Ventilador en versión empennada orientable para tamaños 400-630, orientación fija para tamaños 710-2000. Ver pág. 2.7.

Construcciones especiales

Ver págs. de 2.20 a 2.30.

Clases de rotores

La tabla arriba hace referencia a condiciones de trabajo estándares, en condiciones de funcionamiento pesadas, se aconseja llamar al Servicio de atención al cliente de CORAL para conocer el tipo de rotor más adecuado.

PRH

Tipo • Type • Type • Typ • Tipo		P inst. [kW]	n	LpA [dB(A)]	Tolleranza sulla portata ±5% • Tolérance sur le débit ±5% • Load tolerance ±5% • Durchsatztoleranz ±5% • Tolerancia respecto caudal ±5%														
Ventilatore • Ventilateur • Fan • Ventilator • Ventilador	Motore • Moteur • Motor • Motor • Motor				Q [m³/h]														
					3240	3600	3960	4320	4680	5400	6120	7200	7920	9000	10080	10800	12600	14400	
					pt[mmH ₂ O]														
PRH400/2	112	4	2940	67	251	249	244	238	235										
PRH400/2	132	5,5	2950	72	254	251	246	240	237	220	206	183	165						
PRH450/2R	132	7,5	2950	72		309	309	308	305	296	285	266	253	233	211	192			
PRH450/2	132	7,5	2950	70			325	324	323	316	306	288	275						
PRH450/2	160	11	2955	74			325	324	323	316	306	288	275	256	236	221	167		
PRH500/2R	160	11	2955	73					370	370	365	352	342	324	307	295			
PRH500/2	160	15	2960	77						402	401	393	385	370	354	342	313	282	
PRH560/2R	160	18,5	2960	74								469	467	459	448	439	414		
PRH560/2R	180	22	2960	77								469	467	459	448	439	414	388	
PRH560/2	180	22	2960	75									505	501	494	487	465	440	
PRH560/2	200	30	2960	79									505	501	494	487	465	440	
PRH630/2R	200	30	2960	77											579	577	565	547	
PRH630/2R	200	37	2960	81											579	577	565	547	
PRH630/2	200	37	2960	78													634	626	
PRH630/2	225	45	2960	82													634	626	
PRH710/2R	250	55	2960	80														721	
PRH710/2R	280	75	2960	83														721	
PRH710/2	280	75	2960	81															
PRH710/2	280	90	2960	85															
PRH800/2R	315	110	2970	83															
PRH800/2R	315	132	2970	87															
PRH800/2	315	132	2970	84															
PRH800/2	315	160	2970	88															
PRH630/4R	112	4	1455	64					140	139	138	132	127	121	115	109			
PRH630/4	132	5,5	1455	69						154	153	149	147	142	135	130	121	106	
PRH710/4R	132	7,5	1460	70								176	174	171	166	162	152	140	
PRH710/4	160	11	1460	71									198	197	193	190	180	171	
PRH800/4R	160	15	1460	74											232	231	229	221	
PRH800/4	180	18,5	1460	74												250	250	246	
PRH900/4R	200	30	1470	77														300	
PRH900/4	225	37	1470	77															
PRH1000/4R	225	45	1470	80															
PRH1000/4	250	55	1470	81															
PRH1120/4R	280	75	1480	82															
PRH1120/4	315	110	1480	83															
PRH1250/4R	315	160	1480	85															
PRH1250/4	315	200	1480	86															
PRH1400/4R	315	250	1480	88															
PRH1400/4	315	315	1480	89															
PRH900/6R	160	7,5	970	65										130	130	129	127	124	
PRH900/6	160	11	970	69											140	140	139	135	
PRH1000/6R	180	15	975	72													160	159	
PRH1000/6	200	18,5	975	72														173	
PRH1120/6R	200	22	975	73															
PRH1120/6	225	30	980	75															
PRH1250/6R	280	45	985	76															
PRH1250/6	280	55	985	77															
PRH1400/6R	315	75	985	80															
PRH1400/6	315	90	985	81															

Il livello di pressione sonora ponderato A, LpA (cap.14), corrisponde al valore rilevato, nelle condizioni di prova, nel punto di massima rumorosità.

Tolleranza sulla rumorosità ±4dB(A)
 • Tolérance sur le bruit ±4dB(A) • Noise tolerance ±4dB(A)
 • Geräushtoleranz ±4dB(A) • Tolerancia respecto a ruido ±4dB(A)

Q [m³/h]																					
16200	18000	19800	21600	25200	28800	32400	36000	39600	43200	46800	54000	61200	68400	75600	86400	97200	108000	122400	140000	158000	176000
pt[mmH ₂ O]																					
242																					
361	332	297																			
415	389	361	329																		
525																					
525	502	478	454	402	329																
606	586																				
606	586	564	542	496	447	383															
714	701	684	665	624																	
714	701	684	665	624	581	537	487	422													
811	807	798	786	753	714	674															
811	807	798	786	753	714	674	633	591	542	480											
			960	946	921	890	854	817													
			960	946	921	890	854	817	780	742	659	543									
				1034	1018	994	964	929	894												
				1034	1018	994	964	929	894	858	785	703	592								
128	116																				
162	152	142	128																		
211	204	194	188	167	143																
240	229	222	216	197	176	155															
299	296	291	284	269	253	237	220	200	174												
321	320	317	312	299	284	269	253	236	218	194											
		366	365	358	347	334	319	304	290	274	239										
			397	395	388	377	364	351	337	322	293	258	208								
				451	446	438	427	415	402	375	348	318	282								
					504	501	495	487	476	453	428	402	376	329	260						
							581	576	571	556	540	511	488	451	410	367					
								630	629	620	603	586	561	520	491	452	394				
										702	694	684	663	630	596	563	523	457	357		
											790	790	775	755	730	698	657	600	540	465	
119	112	108	103																		
131	126	120	116	107	93	76															
158	154	150	147	137	128	117	104	88													
173	172	169	166	157	147	138	127	118	103												
197	197	195	192	188	177	171	162	153	143	133											
		220	220	218	213	207	197	190	180	171	155	124									
				257	255	252	246	240	232	225	209	193	174	150							
					278	277	274	269	263	256	241	226	211	194	159						
							310	308	305	300	288	274	260	245	222	193					
								349	349	349	347	340	329	317	303	283	262	239	196		

■ Le niveau de pression sonore pondérée A, LpA (chap. 14), correspond à la valeur relevée dans les conditions d'essai au point de niveau sonore maximum.

■ Der nach A bewertete Schalldruckpegel LpA (Kap. 14) entspricht in den Testbedingungen dem höchsten gemessenen Wert des Geräuschpegels.

■ The A-weighted sound power level, LpA (Chap.14), is the value measured in test conditions at the point of maximum noise level.

■ El nivel de presión sonora ponderado A, LpA (cap. 14), corresponde al valor medido, en las condiciones de prueba, en el punto con máximos niveles de ruido.

PRH

Tipo • Type • Type • Typ • Tipo		P inst. [kW]	n	LpA [dB(A)]	Tolleranza sulla portata $\pm 5\%$ • Tolérance sur le débit $\pm 5\%$ • Load tolerance $\pm 5\%$ • Durchsatztoleranz $\pm 5\%$ • Tolerancia respecto caudal $\pm 5\%$														
Ventilatore • Ventilateur • Fan • Ventilator • Ventilador	Motore • Moteur • Motor • Motor • Motor				Q [m³/h]														
					3240	3600	3960	4320	4680	5400	6120	7200	7920	9000	10080	10800	12600	14400	
					pt[mmH ₂ O]														
PRH400/2		112	4	2940	67	245	243	238	232	229									
PRH400/2		132	5,5	2950	72	247	244	240	234	231	214	200	177	159					
PRH450/2R		132	7,5	2950	72		300	300	299	296	287	276	258	245	225	203	184		
PRH450/2		132	7,5	2950	70			315	314	313	306	296	279	266					
PRH450/2		160	11	2955	74			315	314	313	306	296	279	266	247	227	212	158	
PRH500/2R		160	11	2955	73					357	357	352	340	330	313	297	285		
PRH500/2		160	15	2960	77						387	386	378	370	356	341	329	301	271
PRH560/2R		160	18,5	2960	74								448	446	439	429	420	397	
PRH560/2R		180	22	2960	77								448	446	439	429	420	397	372
PRH560/2		180	22	2960	75									481	477	471	464	444	421
PRH560/2		200	30	2960	79									481	477	471	464	444	421
PRH630/2R		200	30	2960	77											548	546	535	519
PRH630/2R		200	37	2960	81											548	546	535	519
PRH630/2		200	37	2960	78													597	590
PRH630/2		225	45	2960	82													597	590
PRH710/2R		250	55	2960	80														674
PRH710/2R		280	75	2960	83														674
PRH710/2		280	75	2960	81														
PRH710/2		280	90	2960	85														
PRH800/2R		315	110	2970	83														
PRH800/2R		315	132	2970	87														
PRH800/2		315	132	2970	84														
PRH800/2		315	160	2970	88														
PRH630/4R		112	4	1455	64					138	137	136	130	125	119	113	107		
PRH630/4		132	5,5	1455	69						152	150	146	144	139	132	127	118	103
PRH710/4R		132	7,5	1460	70							173	171	168	163	159	149	137	
PRH710/4		160	11	1460	71								194	193	189	186	176	167	
PRH800/4R		160	15	1460	74											227	226	223	216
PRH800/4		180	18,5	1460	74												244	244	240
PRH900/4R		200	30	1470	77														291
PRH900/4		225	37	1470	77														
PRH1000/4R		225	45	1470	80														
PRH1000/4		250	55	1470	81														
PRH1120/4R		280	75	1480	82														
PRH1120/4		315	110	1480	83														
PRH1250/4R		315	160	1480	85														
PRH1250/4		315	200	1480	86														
PRH1400/4R		315	250	1480	88														
PRH1400/4		315	315	1480	89														
PRH900/6R		160	7,5	970	65									128	128	127	125	122	
PRH900/6		160	11	970	69										138	138	137	133	
PRH1000/6R		180	15	975	72												157	156	
PRH1000/6		200	18,5	975	72														170
PRH1120/6R		200	22	975	73														
PRH1120/6		225	30	980	75														
PRH1250/6R		280	45	985	76														
PRH1250/6		280	55	985	77														
PRH1400/6R		315	75	985	80														
PRH1400/6		315	90	985	81														

Il livello di pressione sonora ponderato A, LpA (cap.14), corrisponde al valore rilevato, nelle condizioni di prova, nel punto di massima rumorosità.

Tolleranza sulla rumorosità ±4dB(A)

- Tolérance sur le bruit ±4dB(A) • Noise tolerance ±4dB(A)
- Geräushtoleranz ±4dB(A) • Tolerancia respecto a ruido ±4dB(A)

Q [m³/h]																						
16200	18000	19800	21600	25200	28800	32400	36000	39600	43200	46800	54000	61200	68400	75600	86400	97200	108000	122400	140000	158000	176000	
pt[mmH ₂ O]																						
232																						
347	319	285																				
397	372	345	315																			
499																						
499	477	455	433	383	314																	
572	553																					
572	553	533	513	470	424	363																
667	656	641	624	587																		
667	656	641	624	587	548	507	460	399														
752	748	740	730	701	666	630																
752	748	740	730	701	666	630	593	554	509	450												
			878	866	845	818	787	755														
			878	866	845	818	787	755	722	689	614	507										
				940	926	906	881	851	821													
				940	926	906	881	851	821	789	725	651	549									
125	113																					
158	148	138	124																			
206	199	189	183	162	138																	
234	223	216	210	191	170	149																
290	287	282	275	261	245	229	212	192	166													
311	310	307	302	289	275	260	244	227	209	185												
		353	352	345	335	322	308	293	280	264	230											
			382	380	373	363	350	338	324	310	281	247	198									
					432	427	419	409	398	385	360	334	305	270								
						480	477	471	464	454	432	409	384	359	313	246						
								550	545	541	527	512	486	464	430	391	350					
									593	592	584	569	553	531	493	466	429	374				
										657	650	641	622	593	562	532	495	433	338			
											733	733	720	703	681	652	615	563	508	437		
117	110	106	101																			
129	124	118	113	104	90	72																
155	151	147	144	134	125	114	101	85														
170	169	166	163	154	144	135	124	114	99													
193	193	191	188	184	173	167	158	149	139	129												
		215	215	213	208	202	192	185	175	166	150	119										
			250	248	246	240	234	226	219	203	188	169	145									
				270	269	266	261	256	249	234	219	205	188	153								
						301	299	296	291	279	266	252	237	215	186							
							337	337	337	335	328	318	306	293	273	252	230	187				

■ Le niveau de pression sonore pondérée A, LpA (chap. 14), correspond à la valeur relevée dans les conditions d'essai au point de niveau sonore maximum.

■ Der nach A bewertete Schalldruckpegel LpA (Kap. 14) entspricht in den Testbedingungen dem höchsten gemessenen Wert des Geräuschpegels.

■ The A-weighted sound power level, LpA (Chap.14), is the value measured in test conditions at the point of maximum noise level.

■ El nivel de presión sonora ponderado A, LpA (cap. 14), corresponde al valor medido, en las condiciones de prueba, en el punto con máximos niveles de ruido.

PRH

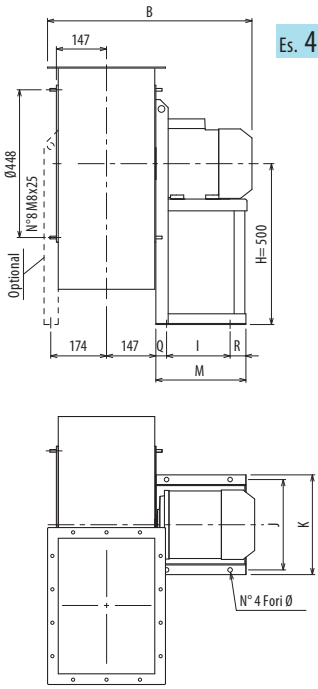

Es. 4

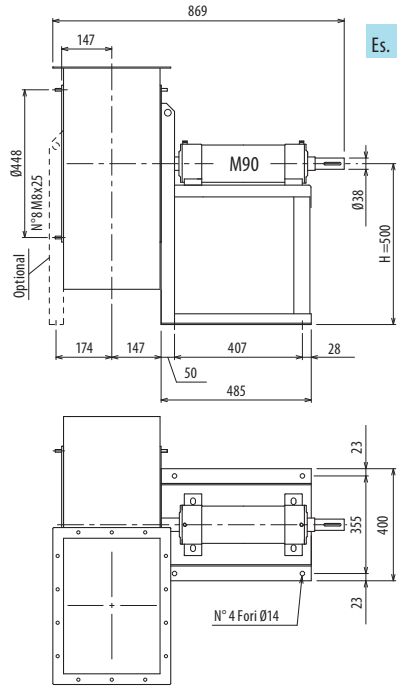

Es. 1

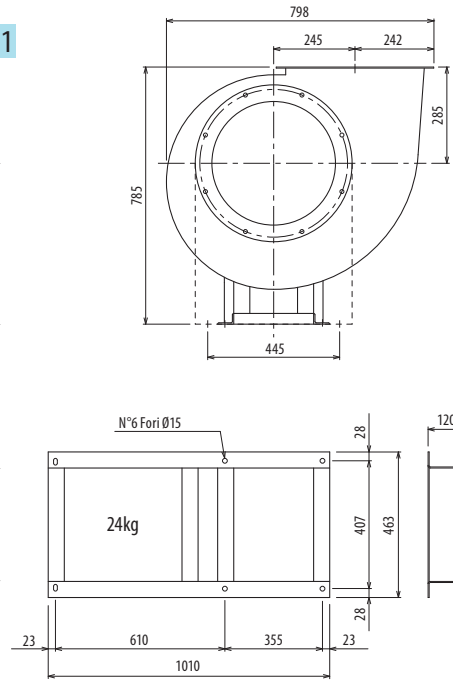

Il ventilatore è orientabile • Peso in tabella comprensivo di motore

- Le ventilateur est orientable ■ The fan is revolvable
- Le poids dans le tableau inclut le moteur The weight indicated in the table includes motor
- Der Ventilator ist drehbar
- Das Gewicht im Tafel schließt den Motor ein
- El ventilador es orientable
- El peso en la tabla incluye el motor

Ulteriori informazioni e cote:
■ Ulterérieures informations et cotes:
■ Further information and sizes:
■ Weitere Infos und Größen:
■ Más informaciones y medidas:

TIPO - Type		PESO Weight	PD ²											
VENTILATORE Fan	MOTORE Motor	Kg	Kgf x m ²	B	I	H	H1	H2	J	K	M	Q	R	Ø
PRH400/2	112 M2	106	1	665	197	500	285	500	289	324	276	30	49	12
PRH400/2	132 SA2	116	1	704	237	500	285	500	337	372	336	40	59	12
PRH400/T		92	1			500	285	500						

pg. / s. 4,6

pg. / s. 4,5

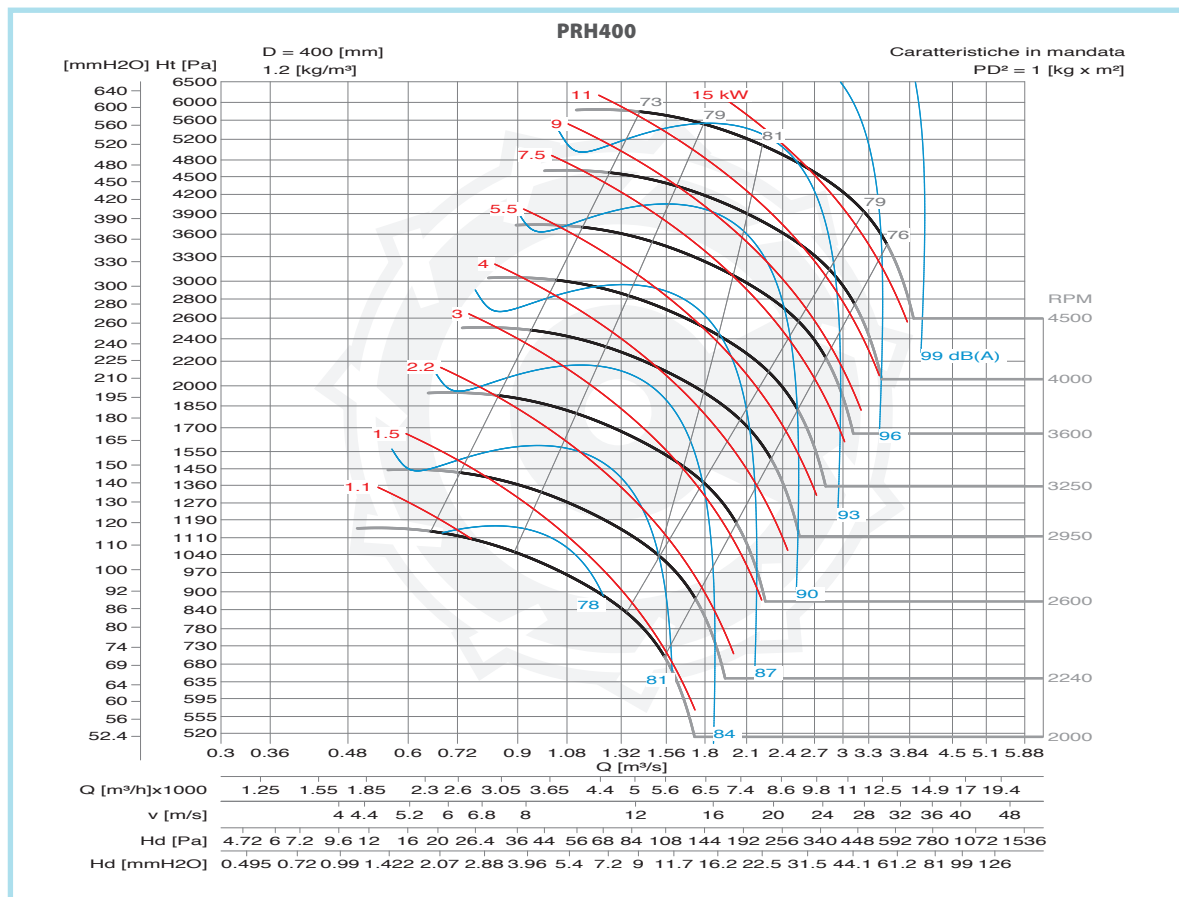
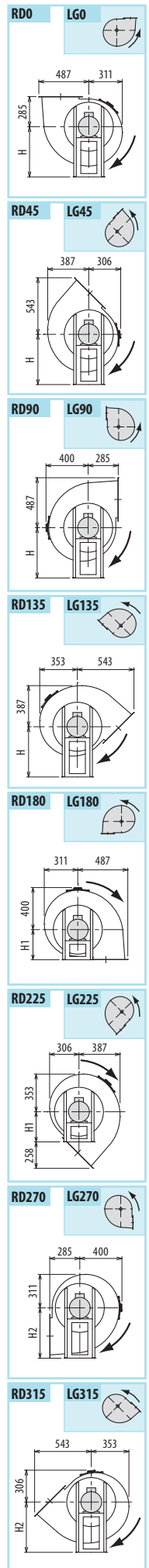
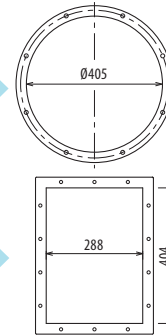

DIMENSIONI D'INGOMBRO E PESI/CURVE DI FUNZIONAMENTO

■ DIMENSIONS D'ENCOMBREMENT ET POIDS/COURBES DE FONCTIONNEMENT ■ OVERALL DIMENSIONS AND WEIGHT/WORKING CURVES
 ■ AUSMARE UND GEWICHTE/FUNKTIONSKURVEN ■ DIMENSIONES QUE OCUPA Y PESOS/CURVAS DE FUNCIONAMIENTO

PRH450



ANTIPOLLUTION SYSTEMS

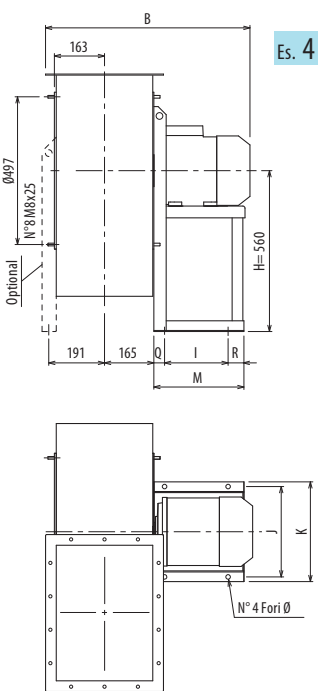

Es. 4

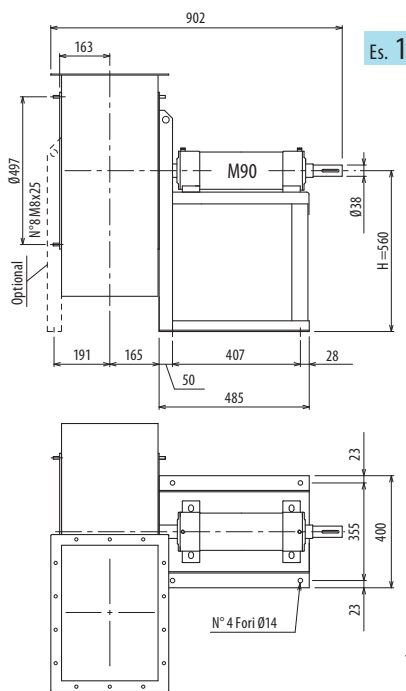

Es. 1

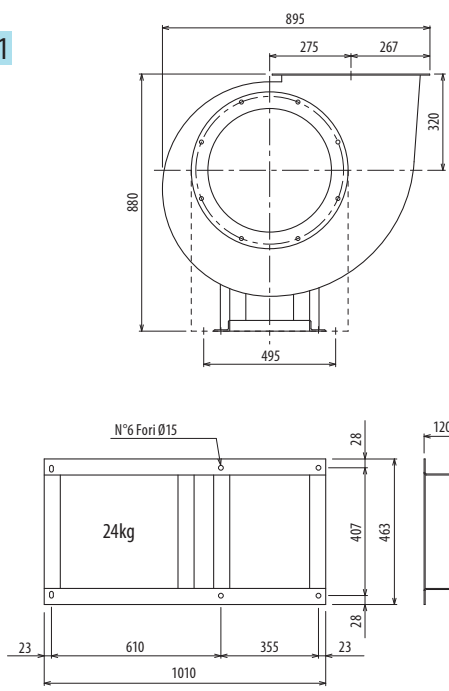

Il ventilatore è orientabile • Peso in tabella comprensivo di motore

- Le ventilateur est orientable ■ The fan is revolvable
- Der Ventilator ist drehbar ■ El ventilador es orientable
- Le poids dans le tableau inclut le moteur The weight indicated in the table includes motor Das Gewicht in Tafel schließt den Motor ein El peso en la tabla incluye el motor

Ulteriori informazioni e quote:
 ■ Ulérieures informations et cotes:
 ■ Further information and sizes:
 ■ Weitere Infos und Größen:
 ■ Más informaciones y medidas:

TIPO - Type		PESO Weight	PD ²											
VENTILATORE Fan	MOTORE Motor	Kg	Kgf x m ²	B	I	H	H1	H2	J	K	M	Q	R	Ø
PRH450/2R	132 SB2	124	1	739	237	560	320	560	337	372	336	40	59	12
PRH450/2	132 SB2	127	1,8	739	237	560	320	560	337	372	336	40	59	12
PRH450/2	160 MA2	161	1,8	844	337	560	320	560	395	440	436	50	49	14
PRH450/T		105	1,8			560	320	560						

pg. / s. 4,6

pg. / s. 4,5

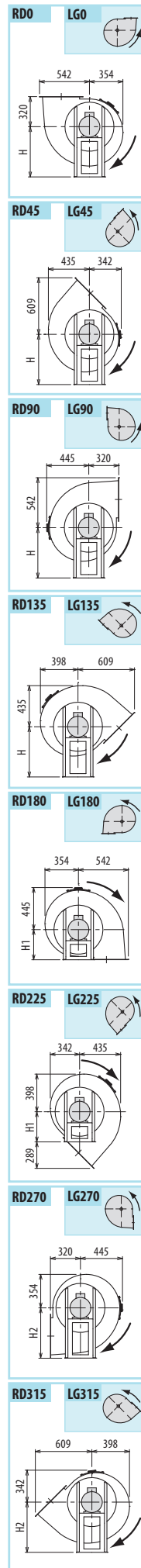
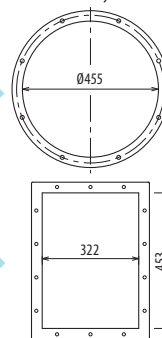

PRH

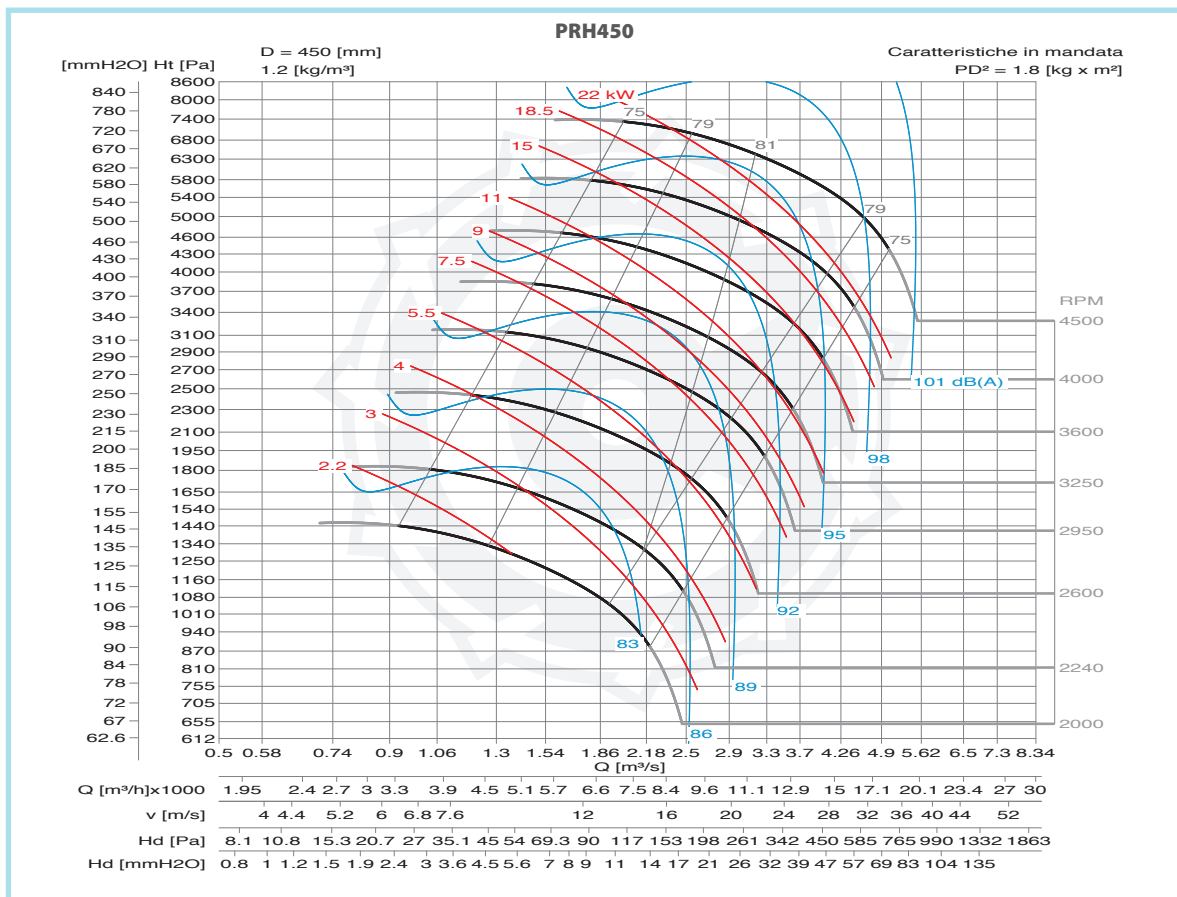

PRH

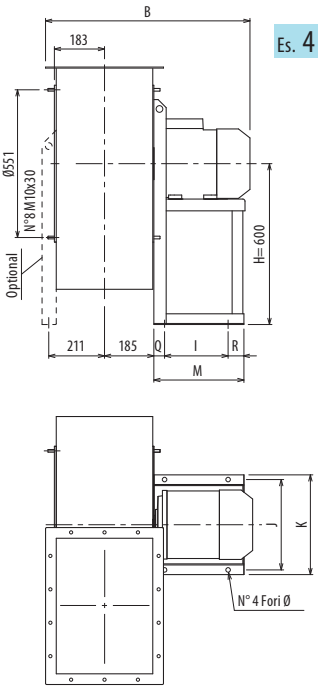

Es. 4

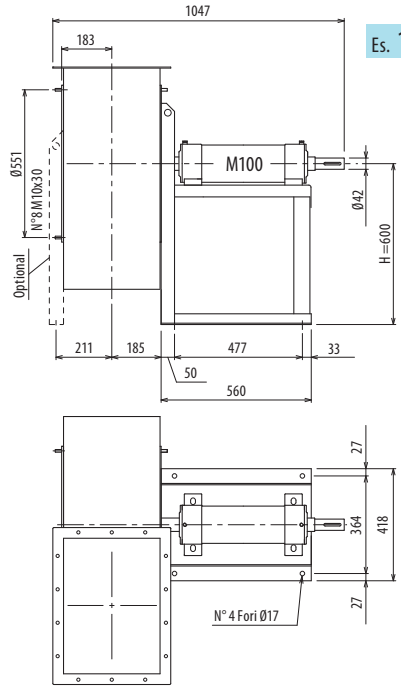

Es. 1

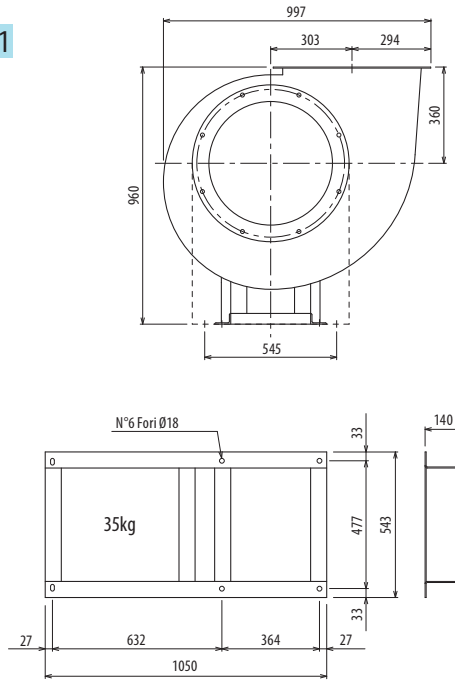

Il ventilatore è orientabile • Peso in tabella comprensivo di motore

- Le ventilateur est orientable
- The fan is revolvable
- Der Ventilator ist drehbar
- El ventilador es orientable
- Le poids dans le tableau inclut le moteur
- The weight indicated in the table includes motor
- Das Gewicht in Tafel schließt den Motor ein
- El peso en la tabla incluye el motor

Ulteriori informazioni e quote:
■ Ulterérieures informations et cotes:
■ Further information and sizes:
■ Weitere Infos und Größen:
■ Más informaciones y medidas:

TIPO - Type		PESO Weight	PD ²											
VENTILATORE Fan	MOTORE Motor	Kg	Kgf x m ²	B	I	H	H1	H2	J	K	M	Q	R	Ø
PRH500/2R	160 MA2	187	2,3	884	337	600	360	600	395	440	436	50	49	14
PRH500/2	160 MB2	199	2,6	884	337	600	360	600	395	440	436	50	49	14
PRH500/T		145	2,6			600	360	600						

pg. / s. 4,6

pg. / s. 4,5

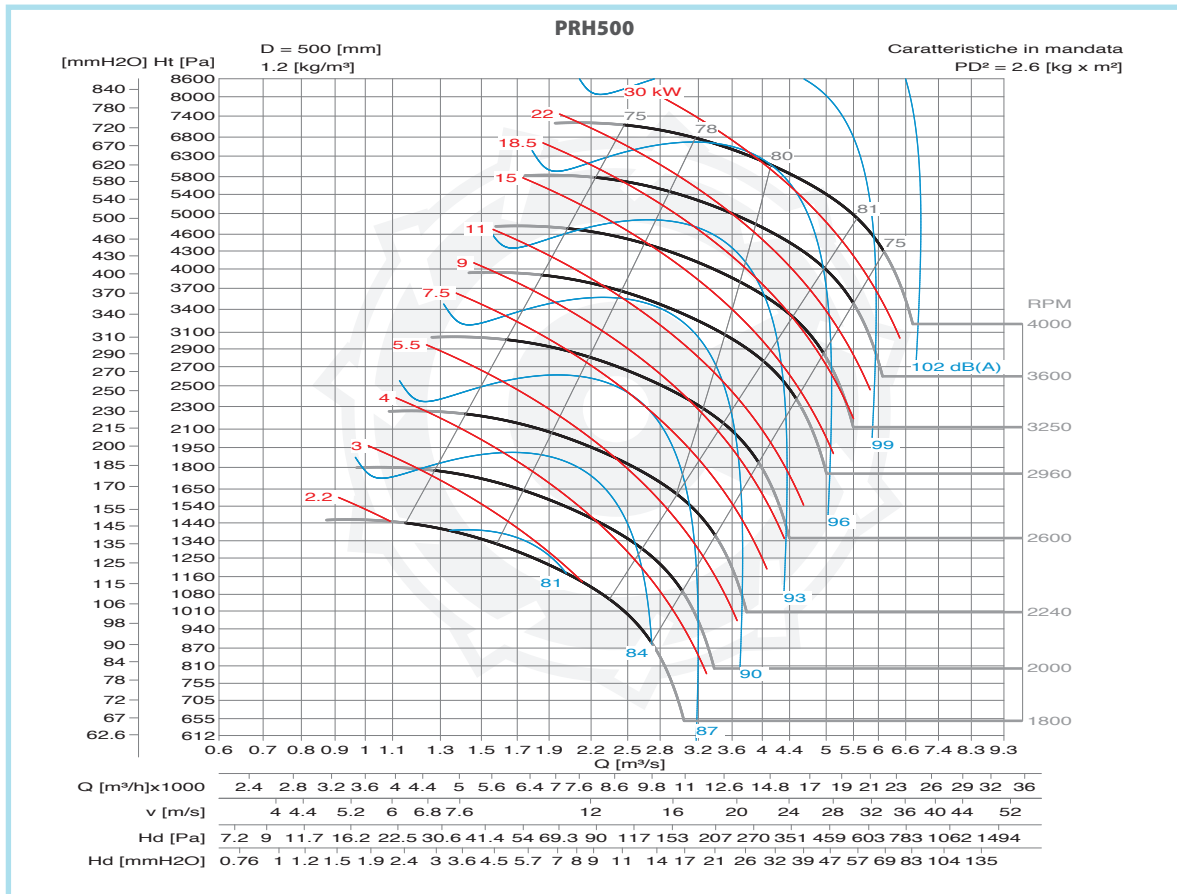
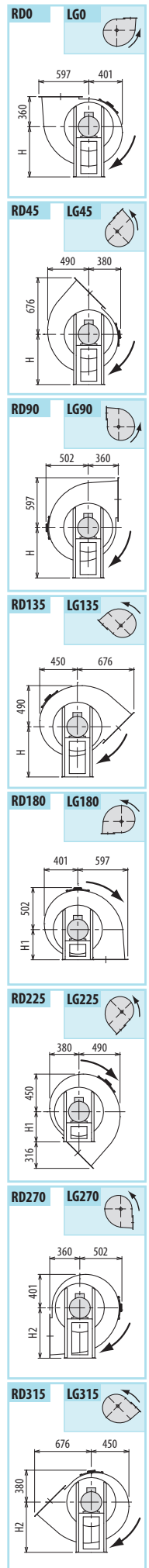
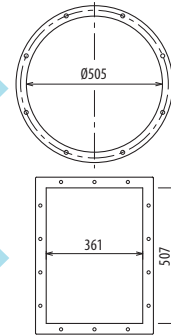

DIMENSIONI D'INGOMBRO E PESI/CURVE DI FUNZIONAMENTO

■ DIMENSIONS D'ENCOMBREMENT ET POIDS/COURBES DE FONCTIONNEMENT ■ OVERALL DIMENSIONS AND WEIGHT/WORKING CURVES
 ■ AUSMARE UND GEWICHTE/FUNKTIONSKURVEN ■ DIMENSIONES QUE OCUPA Y PESOS/CURVAS DE FUNCIONAMIENTO

PRH560

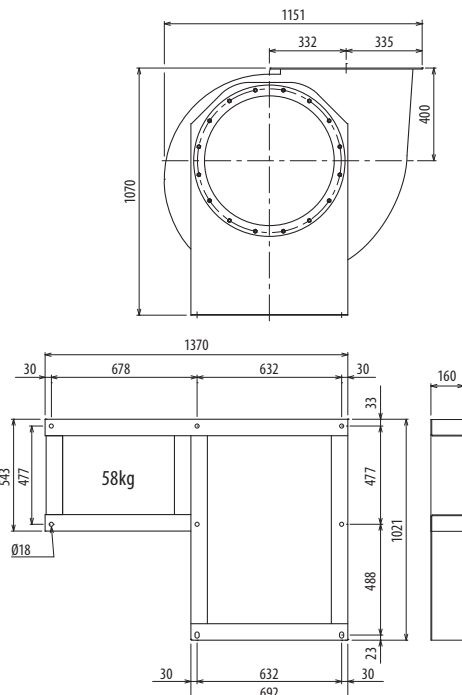
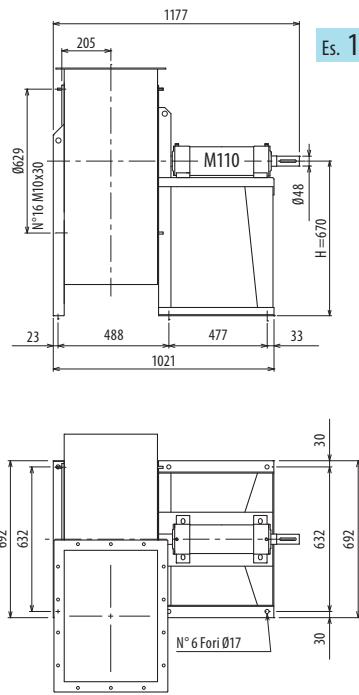
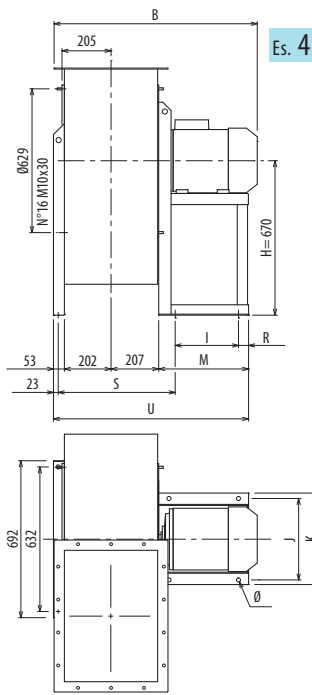

Il ventilatore è orientabile • Peso in tabella comprensivo di motore

- Le ventilateur est orientable
- The fan is revolvable
- Der Ventilator ist drehbar
- El ventilador es orientable
- Le poids dans le tableau inclut le moteur
- The weight indicated in the table includes motor
- Das Gewicht in Tafel schließt den Motor ein
- El peso en la tabla incluye el motor

Ulteriori informazioni e quote:
 ■ Ulérieures informations et cotes:
 ■ Further information and sizes:
 ■ Weitere Infos und Größen:
 ■ Más informaciones y medidas:

TIPO - Type		PESO Weight	PD ²	B	I	H	H1	H2	J	K	M	R	S	U	Ø
VENTILATORE Fan	MOTORE Motor	Kg	Kgf x m ²												
PRH560/2R	160 L2	220	3,6	939	337	670	400	670	395	440	435	49	488	897	14
PRH560/2R	180 M2	273	3,6	1021	357	670	400	670	434	488	460	33	509	922	17
PRH560/2	180 M2	275	4,5	1021	357	670	400	670	434	488	460	33	509	922	17
PRH560/2	200 LA2	353	4,5	1129	381	670	400	670	506	568	500	39	519	962	19
PRH560/T		196	4,5			670	400	670							

pg. / s. 4,6
 pg. / s. 4,5

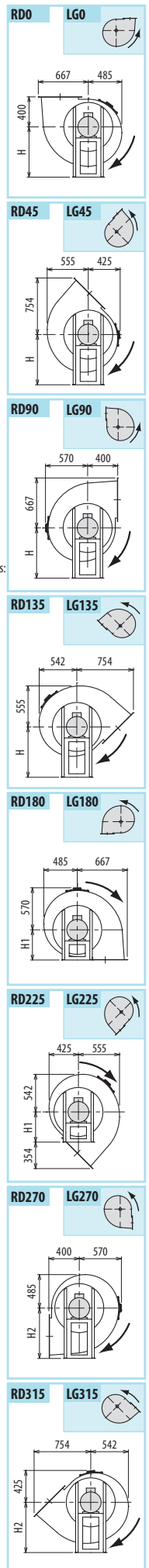
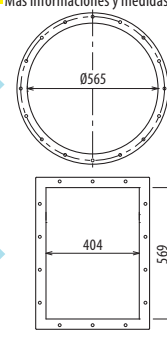

PRH

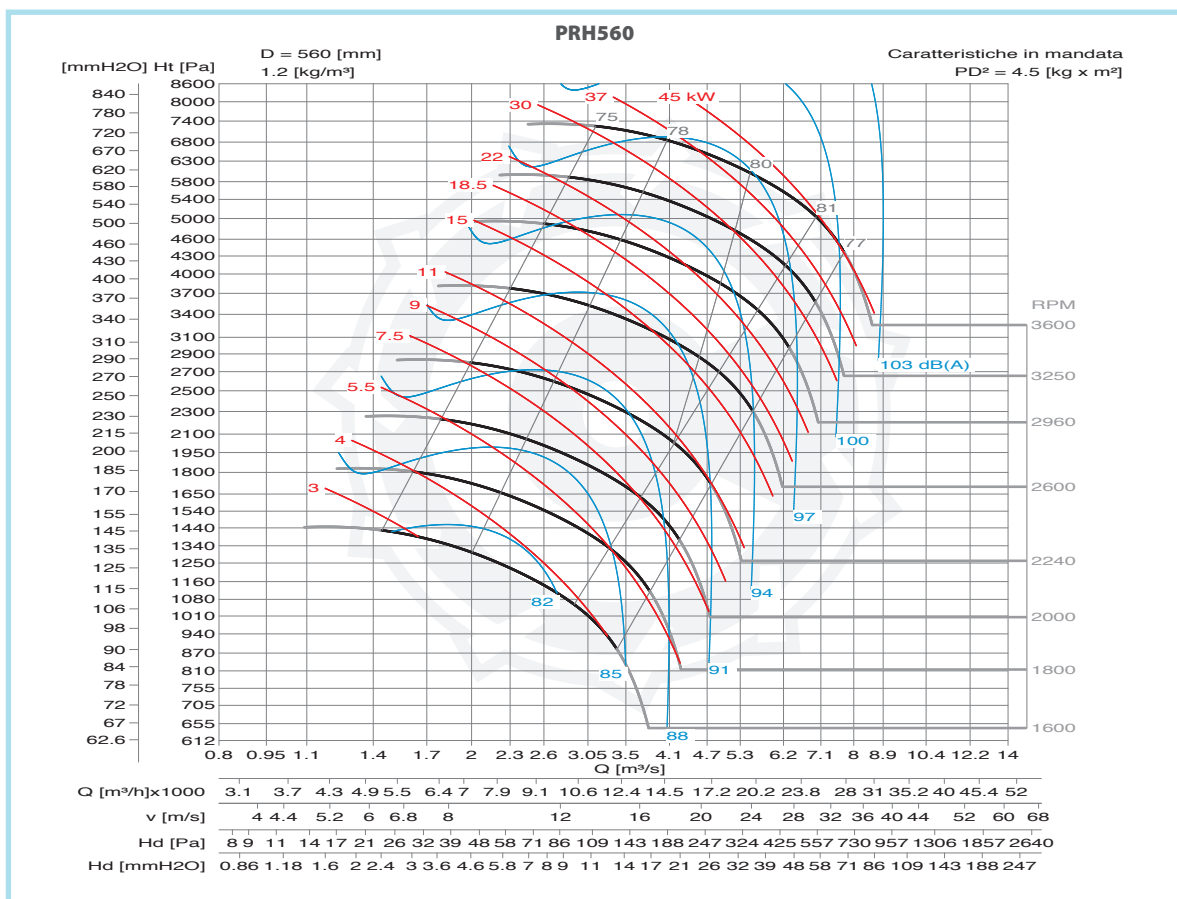

PRH

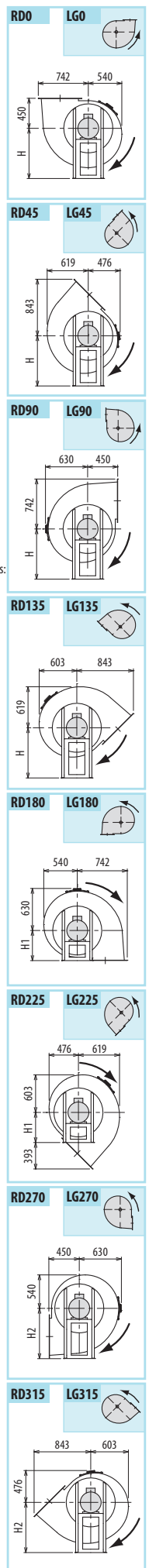
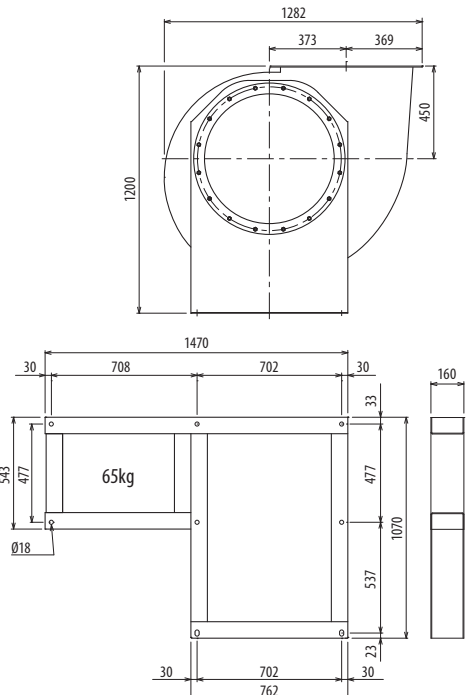
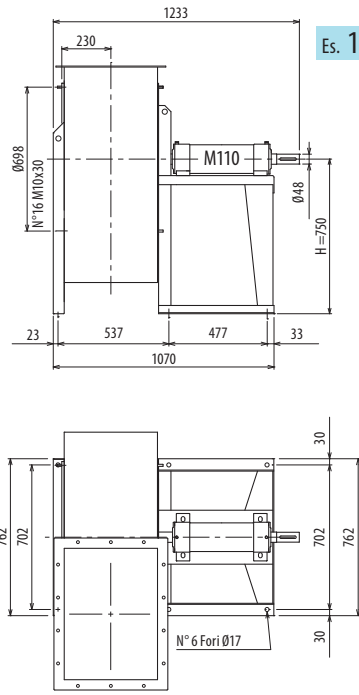
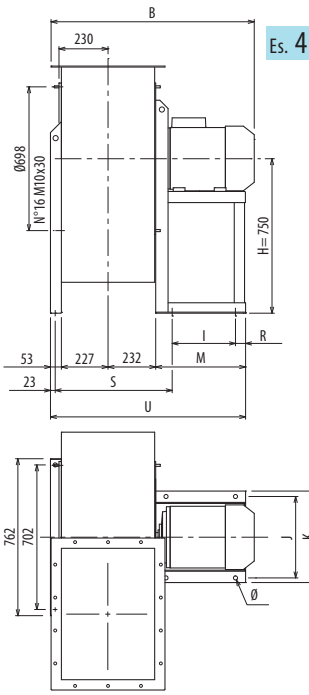

Il ventilatore è orientabile • Peso in tabella comprensivo di motore

- Le ventilateur est orientable
- The fan is revolvable
- Der Ventilator ist drehbar
- El ventilador es orientable
- Further information and sizes:
- Weitere Infos und Größen:
- Más informaciones y medidas:

TIPO - Type		PESO Weight	PD ²	B	I	H	H1	H2	J	K	M	R	S	U	Ø
VENTILATORE Fan	MOTORE Motor	Kg	Kgf x m ²												
PRH630/2R	200 LA2	387	7,4	1179	381	750	450	750	506	568	500	39	568	1011	19
PRH630/2R	200 LB2	387	7,4	1179	381	750	450	750	506	568	500	39	568	1011	19
PRH630/2	200 LB2	389	8,5	1179	381	750	450	750	506	568	500	39	568	1011	19
PRH630/2	225 M2	471	8,5	1221	421	750	450	750	556	616	540	39	568	1051	19
PRH630/4R	112 M4	180	7	845	197	750	450	750	289	324	275	49	517	786	12
PRH630/4	132 S4	202	6,8	885	237	750	450	750	337	372	335	59	527	846	12
PRH630/T		239	8,5			750	450	750							

Ulteriori informazioni e quote:
■ Ulérieures informations et cotes:
■ Further information and sizes:
■ Weitere Infos und Größen:
■ Más informaciones y medidas:

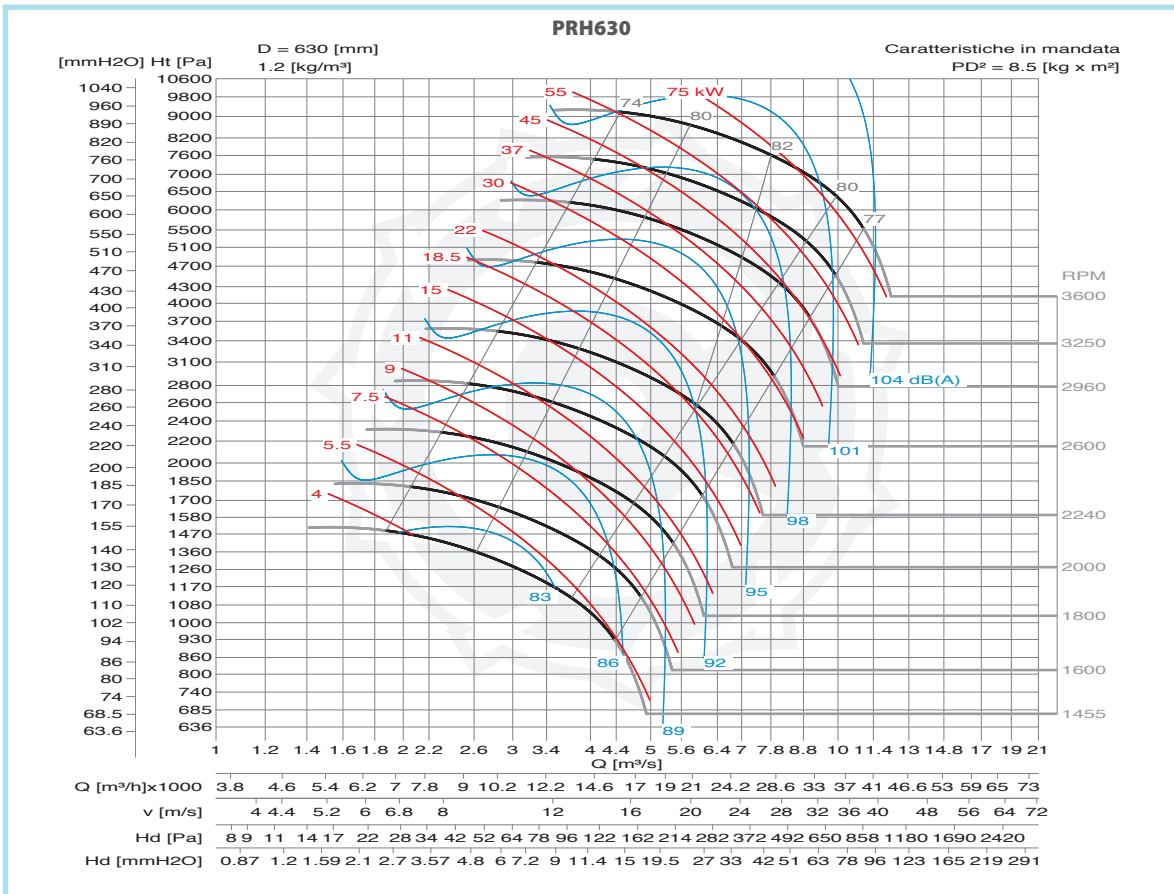
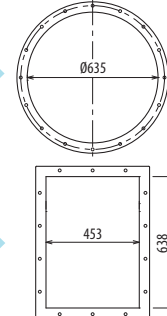

DIMENSIONI D'INGOMBRO E PESI/CURVE DI FUNZIONAMENTO

■ DIMENSIONS D'ENCOMBREMENT ET POIDS/COURBES DE FONCTIONNEMENT ■ OVERALL DIMENSIONS AND WEIGHT/WORKING CURVES
 ■ AUSMARE UND GEWICHTE/FUNKTIONSKURVEN ■ DIMENSIONES QUE OCUPA Y PESOS/CURVAS DE FUNCIONAMIENTO

PRH710



PRH

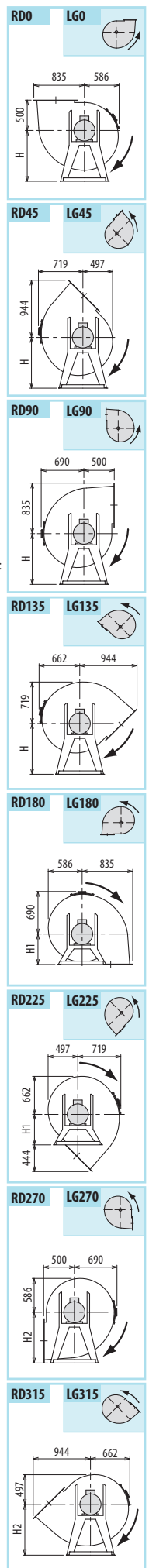
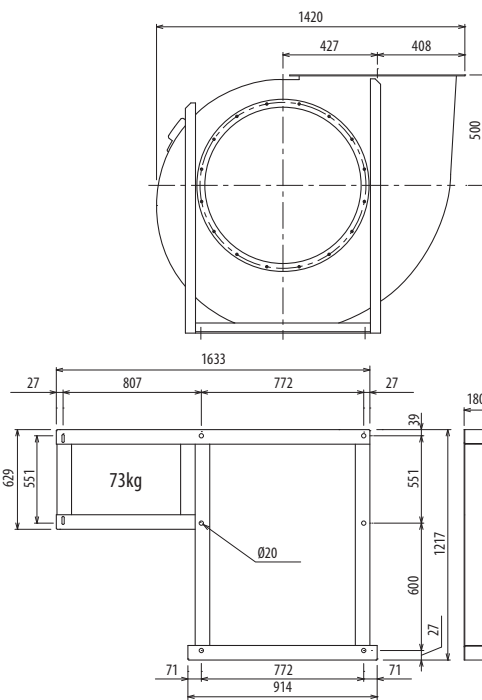
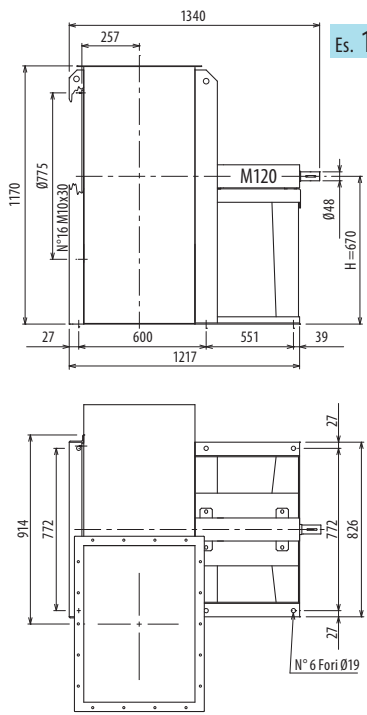
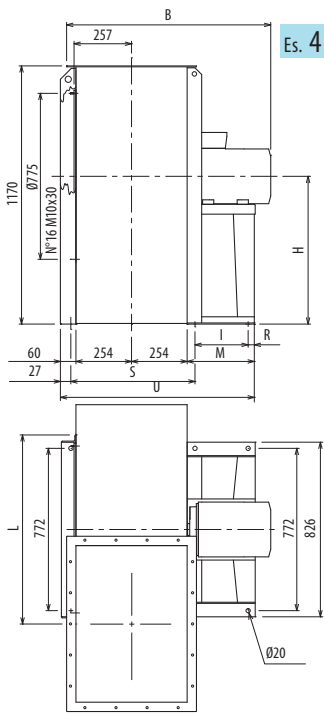

Il ventilatore non è orientabile - Peso in tabella comprensivo di motore

- Le ventilateur n'est pas orientable
- The fan is not revolvable
- Der Ventilator ist nicht drehbar
- El ventilador no es orientable
- Le poids dans le tableau inclut le moteur
- The weight indicated in the table includes motor
- Das Gewicht im Tafel schließt den Motor ein
- El peso en la tabla incluye el motor
- Weitere Infos und Größen:
- Más informaciones y medidas:

TIPO • Type		PESO Weight Kg	PD ² Kgf x m ²	B	I	H	H1	H2	L	R	M	S	U
VENTILATORE Fan	MOTORE Motor												
PRH710/2R	250 M2	630	14	1384	501	670	500	850	832	39	600	606	1173
PRH710/2R	280 S2	760	14	1387	591	670	500	850	832	39	690	606	1263
PRH710/2	280 S2	762	15	1387	591	670	500	850	832	39	690	606	1263
PRH710/2	280 M2	800	15	1387	591	670	500	850	832	39	690	606	1263
PRH710/4R*	132 M4	286	14	940	201	850	500	850	832	75	336	606	909
PRH710/4*	160 M4	315	15	1045	316	850	500	850	832	60	439	606	1009
PRH710/T		360	15			670	500	850					

pg. / s. 4,6

pg. / s. 4,5

* Il ventilatore è orientabile ■ * Le ventilateur est orientable ■ * The fan is revolvable ■ * Der Ventilator ist drehbar ■ * El ventilador es orientable

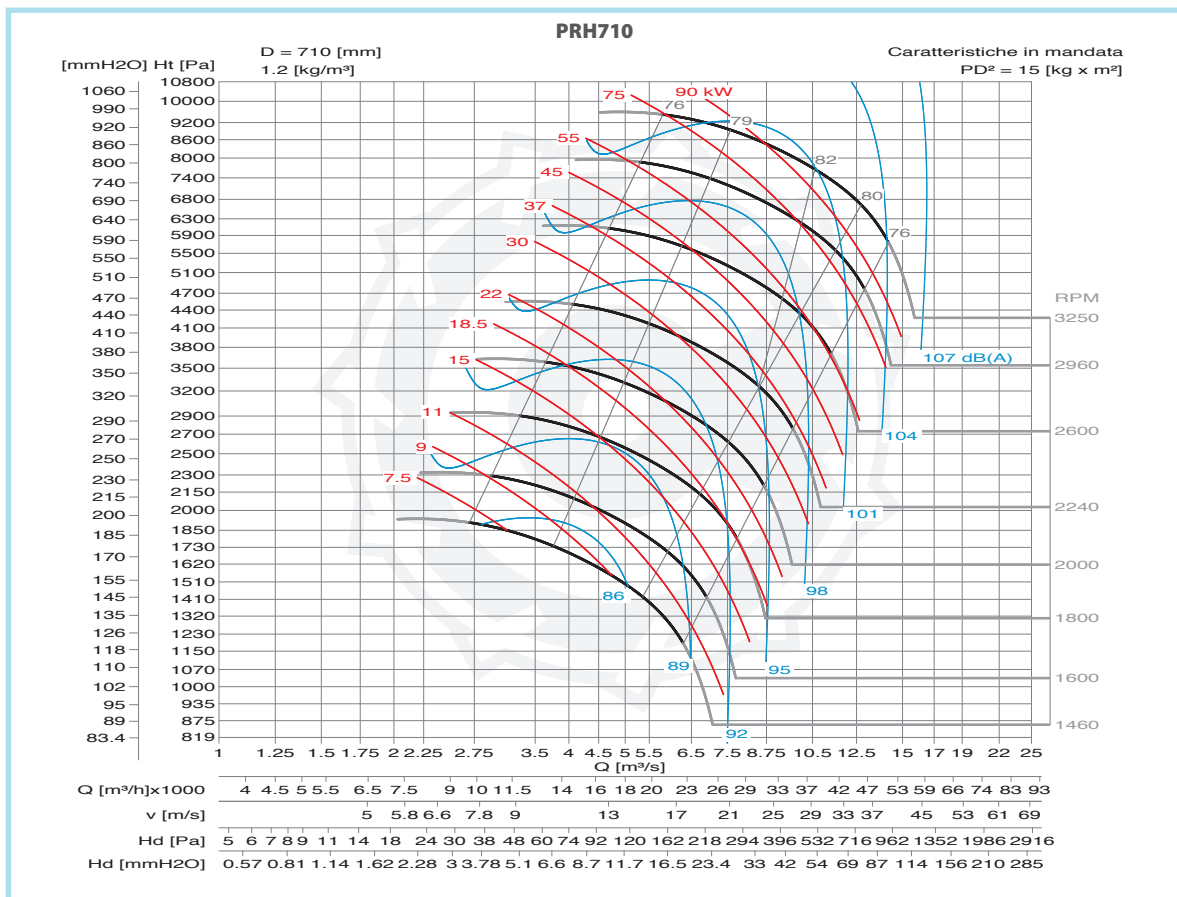

PRH

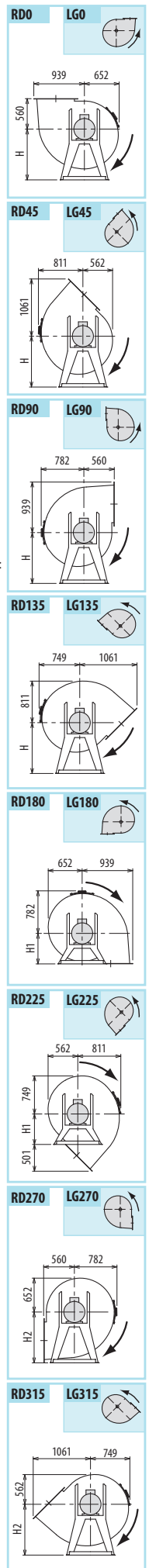
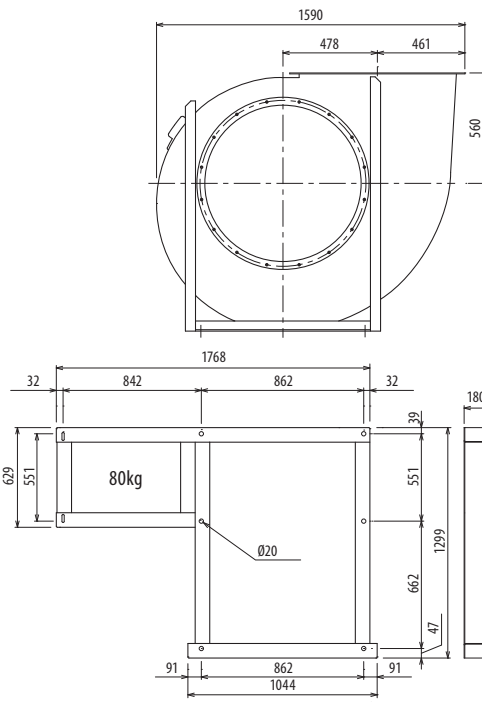
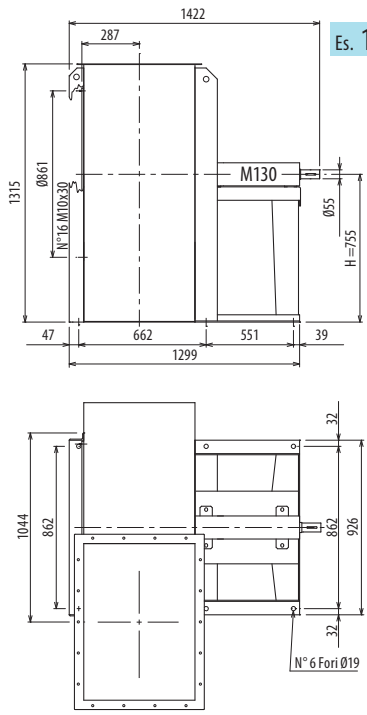
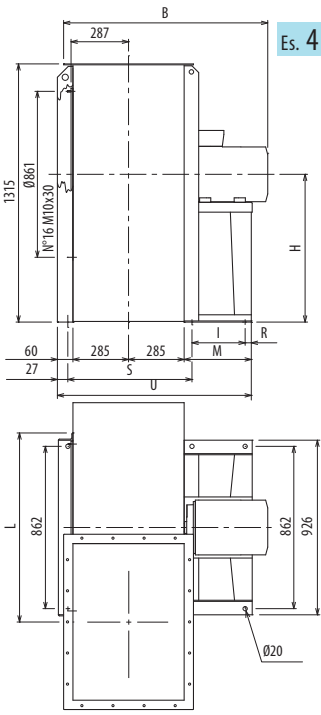

Il ventilatore non è orientabile - Peso in tabella comprensivo di motore

- Le ventilateur n'est pas orientable
- The fan is not revolvable
- Der Ventilator ist nicht drehbar
- El ventilador no es orientable
- Le poids dans le tableau inclut le moteur
- The weight indicated in the table includes motor
- Das Gewicht im Tafel schließt den Motor ein
- El peso en la tabla incluye el motor
- Weitere Infos und Größen:
- Más informaciones y medidas:

TIPO • Type		PESO Weight Kg	PD ² Kgf x m ²	B	I	H	H1	H2	L	R	M	S	U
VENTILATORE Fan	MOTORE Motor												
PRH800/2R	315 S2	1047	27	1561	675	755	560	950	932	65	800	668	1435
PRH800/2R	315 M2	1207	27	1661	675	755	560	950	932	65	800	668	1435
PRH800/2	315 M2	1209	28	1661	675	755	560	950	932	65	800	668	1435
PRH800/2	315 LA2	1259	28	1721	675	755	560	950	932	65	800	668	1435
PRH800/4R*	160 L4	409	27	1107	316	950	560	950	932	60	439	668	1071
PRH800/4*	180 M4	465	28	1188	361	950	560	950	932	39	460	668	1095
PRH800/T		442	28			755	560	950					

Ulteriori informazioni e quote:
■ Ulérieures informations et cotes:
■ Further information and sizes:
■ Weitere Infos und Größen:
■ Más informaciones y medidas:

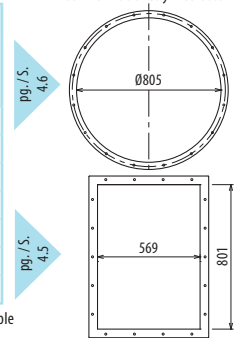

* Il ventilatore è orientabile ■ * Le ventilateur est orientable ■ * The fan is revolvable ■ * Der Ventilator ist drehbar ■ * El ventilador es orientable

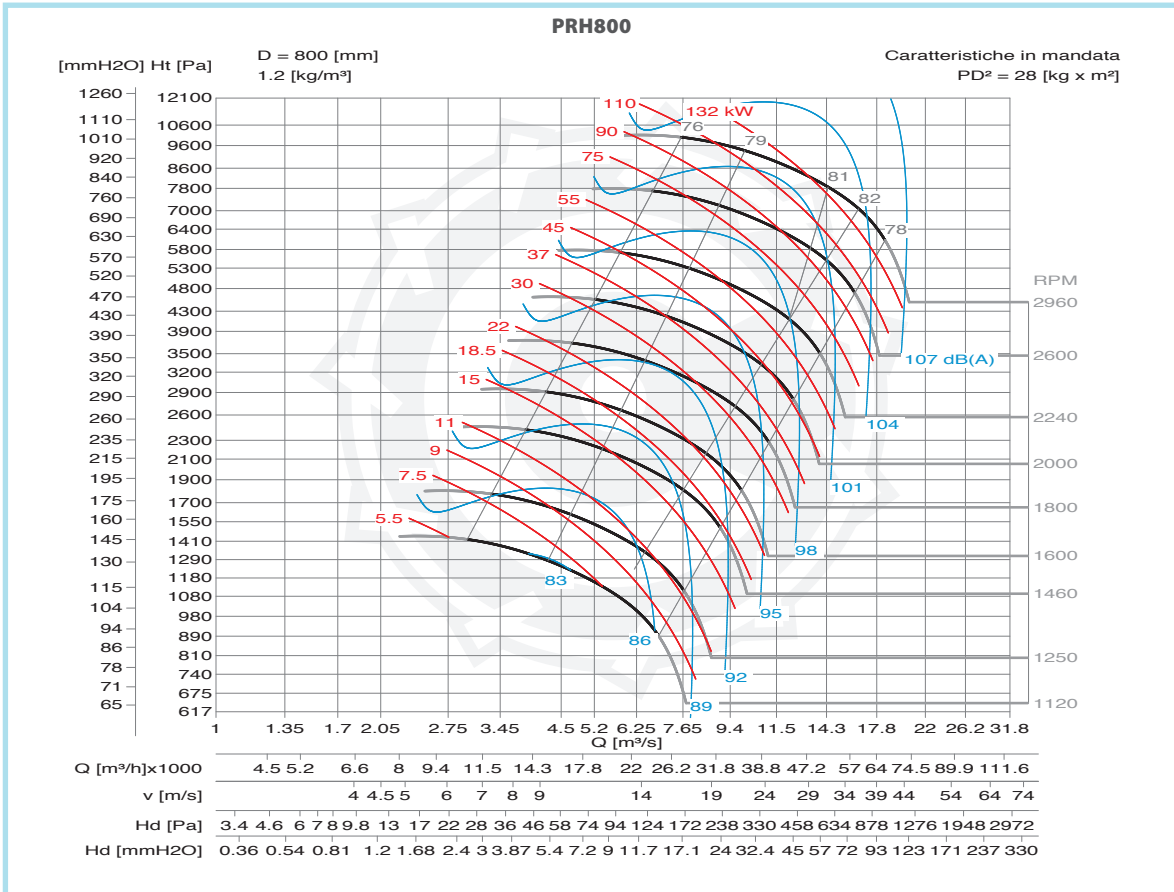

DIMENSIONI D'INGOMBRO E PESI/CURVE DI FUNZIONAMENTO

■ DIMENSIONS D'ENCOMBREMENT ET POIDS/COURBES DE FONCTIONNEMENT ■ OVERALL DIMENSIONS AND WEIGHT/WORKING CURVES
 ■ AUSMARE UND GEWICHTE/FUNKTIONSKURVEN ■ DIMENSIONES QUE OCUPA Y PESOS/CURVAS DE FUNCIONAMIENTO

PRH900



PRH

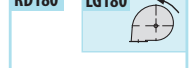
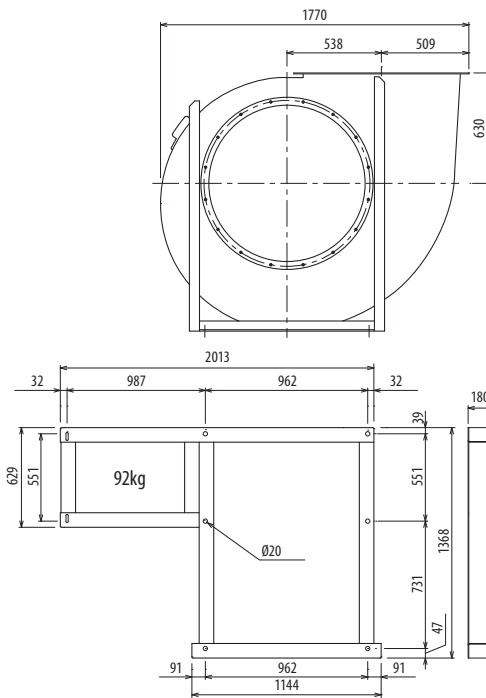
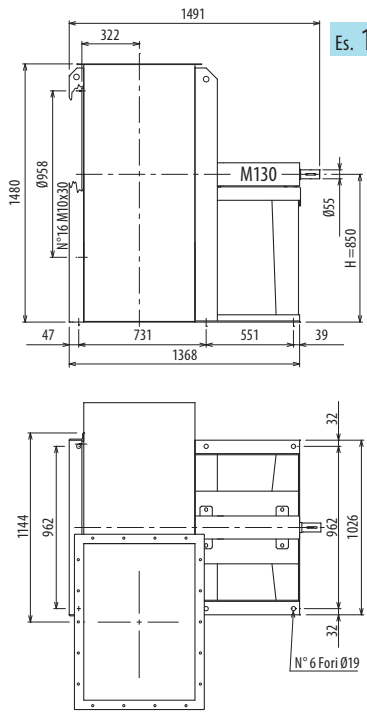
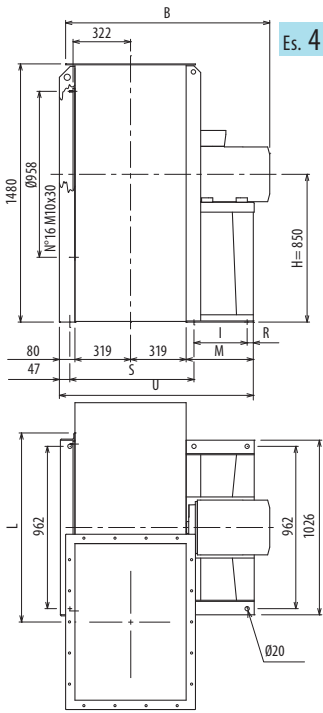

Il ventilatore non è orientabile - Peso in tabella comprensivo di motore

- Le ventilateur n'est pas orientable
- The fan is not revolvable
- Der Ventilator ist nicht drehbar
- El ventilador no es orientable
- Le poids dans le tableau inclut le moteur
- The weight indicated in the table includes motor
- Das Gewicht im Tafel schließt den Motor ein
- El peso en la tabla incluye el motor
- Weitere Infos und Größen:
- Más informaciones y medidas:

Ulteriori informazioni e quote:
 ■ Ulteriores informations et cotes:
 ■ Further information and sizes:
 ■ Weitere Infos und Größen:
 ■ Más informaciones y medidas:

TIPO - Type		PESO Weight	PD ²										
VENTILATORE Fan	MOTORE Motor	Kg	Kgf x m ²	B	I	H	H1	H2	L	R	M	S	U
PRH900/4R	200 L4	790	39	1385	401	850	630	1060	1145	39	500	731	1218
PRH900/4	225 S4	840	44	1367	441	850	630	1060	1145	39	540	731	1258
PRH900/6R	160 M6	544	39	1196	316	850	630	1060	1145	60	436	731	1154
PRH900/6	160 L6	556	44	1196	316	850	630	1060	1145	60	436	731	1154
PRH900/T		570	44			850	630	1060					

pg. / s. 4,6

pg. / s. 4,5

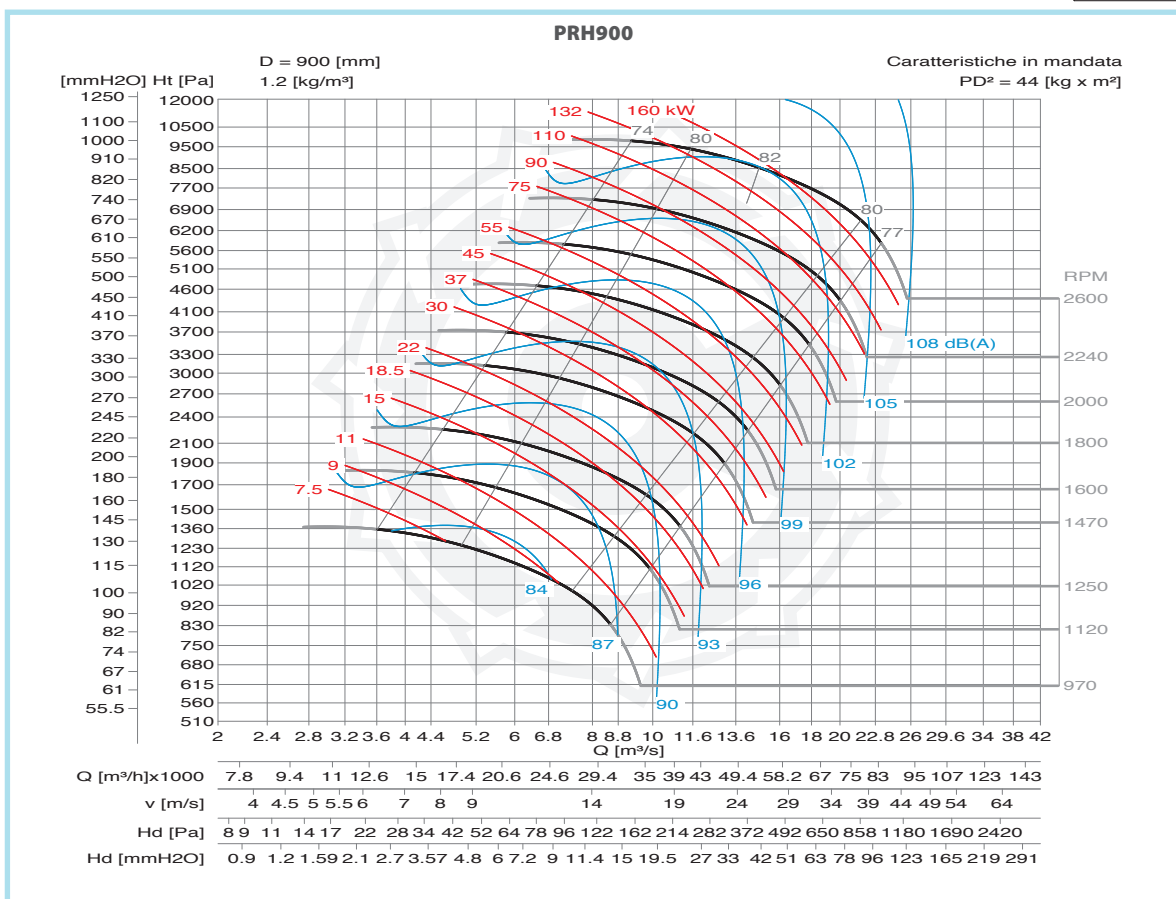
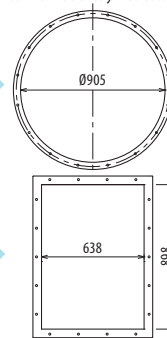

PRH

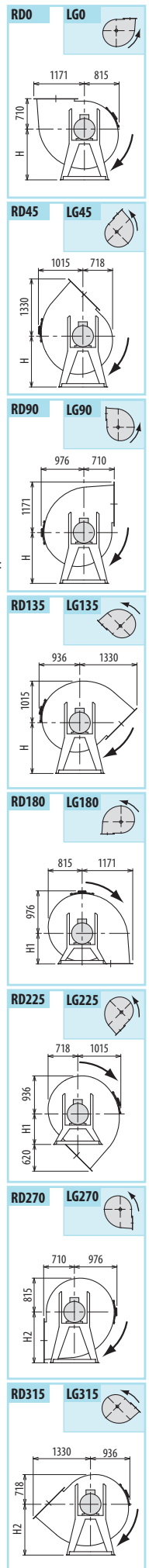
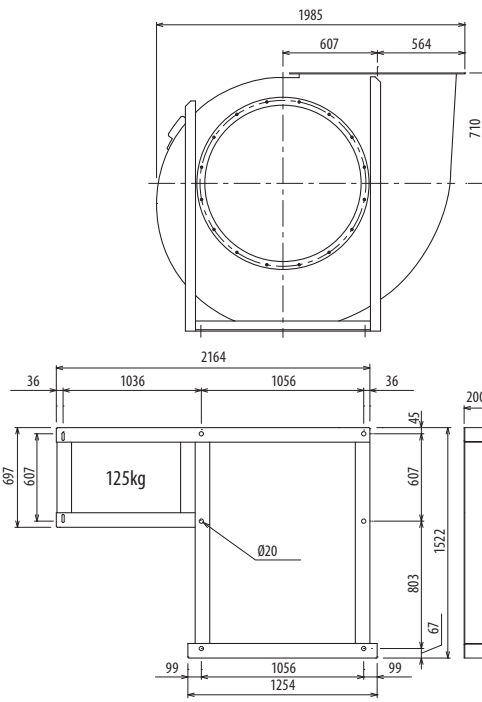
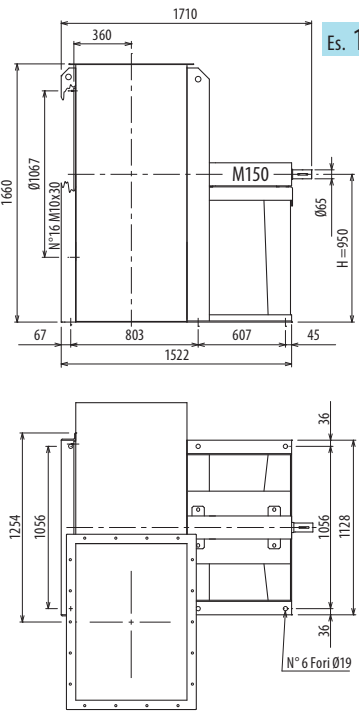
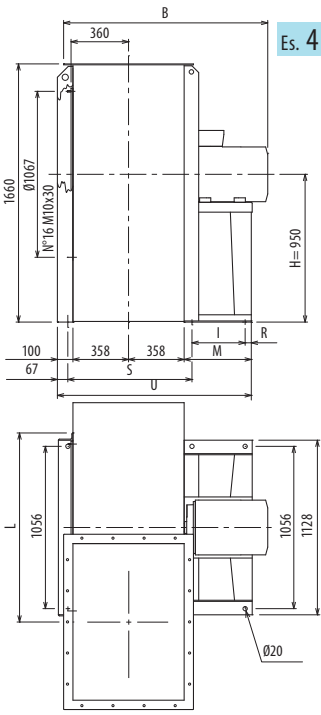

Il ventilatore non è orientabile - Peso in tabella comprensivo di motore

■ Le ventilateur n'est pas orientable
Le poids dans le tableau inclut le moteur

■ The fan is not revolvable
The weight indicated in the table includes motor

■ Der Ventilator ist nicht drehbar
Das Gewicht im Tafel schließt den Motor ein

■ El ventilador no es orientable
El peso en la tabla incluye el motor

Ulteriori informazioni e quote:

■ Ulteriores informations et cotes:
Further information and sizes:
■ Weitere Infos und Größen:
Más informaciones y medidas:

TIPO • Type		MOTORE Motor	PESEO Weight Kg	PD ² Kgf x m ²	B	I	H	H1	H2	L	R	M	S	U
VENTILATORE Fan														
PRH1000/4R		225 M4	1020	69	1464	440	950	710	1180	1255	45	540	803	1355
PRH1000/4		250 M4	1105	74	1632	500	950	710	1180	1255	45	600	803	1415
PRH1000/6R		180 L6	811	64	1374	360	950	710	1180	1255	45	460	803	1275
PRH1000/6		200 LA6	885	69	1482	400	950	710	1180	1255	45	500	803	1315
PRH1000/T			800	74			950	710	1180					

pg. / s. 4,6

pg. / s. 4,5

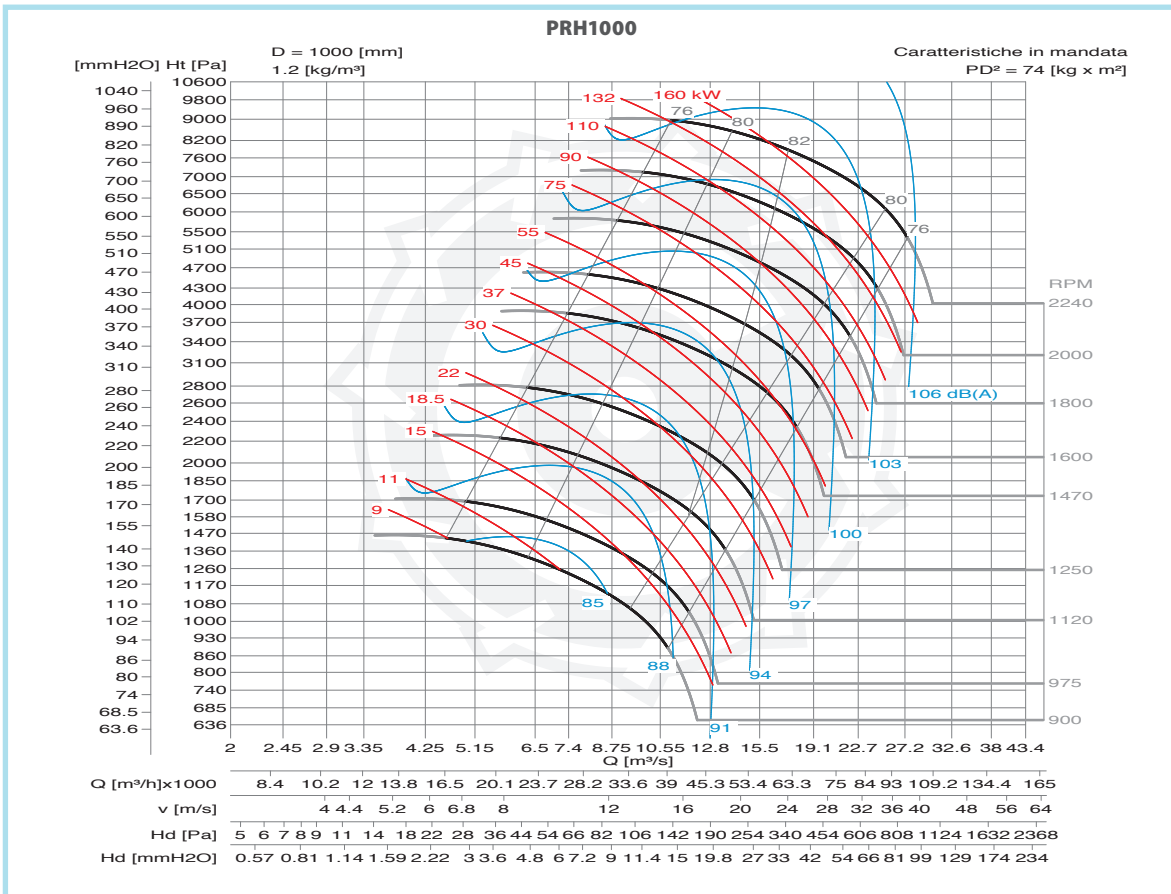
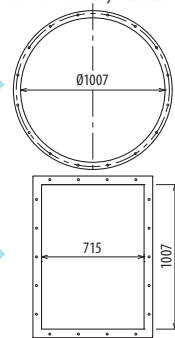

DIMENSIONI D'INGOMBRO E PESI/CURVE DI FUNZIONAMENTO

■ DIMENSIONS D'ENCOMBREMENT ET POIDS/COURBES DE FONCTIONNEMENT ■ OVERALL DIMENSIONS AND WEIGHT/WORKING CURVES
 ■ AUSMARE UND GEWICHTE/FUNKTIONSKURVEN ■ DIMENSIONES QUE OCUPA Y PESOS/CURVAS DE FUNCIONAMIENTO

PRH1120



PRH

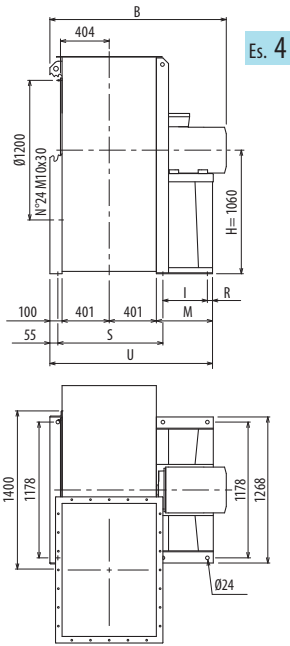

Es. 4

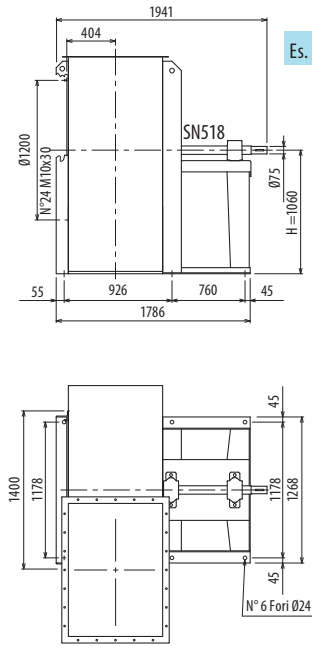

Es. 1

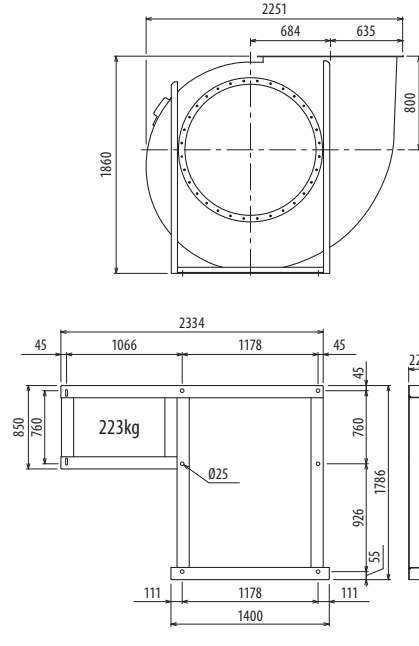

Il ventilatore non è orientabile - Peso in tabella comprensivo di motore

- Le ventilateur n'est pas orientable
- The fan is not revolvable
- Der Ventilator ist nicht drehbar
- El ventilador no es orientable
- Le poids dans le tableau inclut le moteur
- The weight indicated in the table includes motor
- Das Gewicht in Tafel schließt den Motor ein
- El peso en la tabla incluye el motor
- Más informaciones y medidas:

Ulteriori informazioni e quote:
 ■ Ulérieures informations et cotes:
 ■ Further information and sizes:
 ■ Weitere Infos und Größen:
 ■ Más informaciones y medidas:

TIPO - Type		PESO Weight Kg	PD ² Kg x m ²	B	I	H	H1	H2	R	S	M	U
VENTILATORE Fan	MOTORE Motor											
PRH1120/4R	280 S4	1293	116	1722	565	1060	800	1320	45	926	690	1591
PRH1120/4	315 S4	1493	133	1934	675	1060	800	1320	45	926	800	1701
PRH1120/6R	200 LB6	998	113	1569	375	1060	800	1320	45	926	500	1401
PRH1120/6	225 M6	1153	130	1611	415	1060	800	1320	45	926	540	1441
PRH1120/T		1065	133			1060	800	1320				

pg. / s. 4,6

pg. / s. 4,5

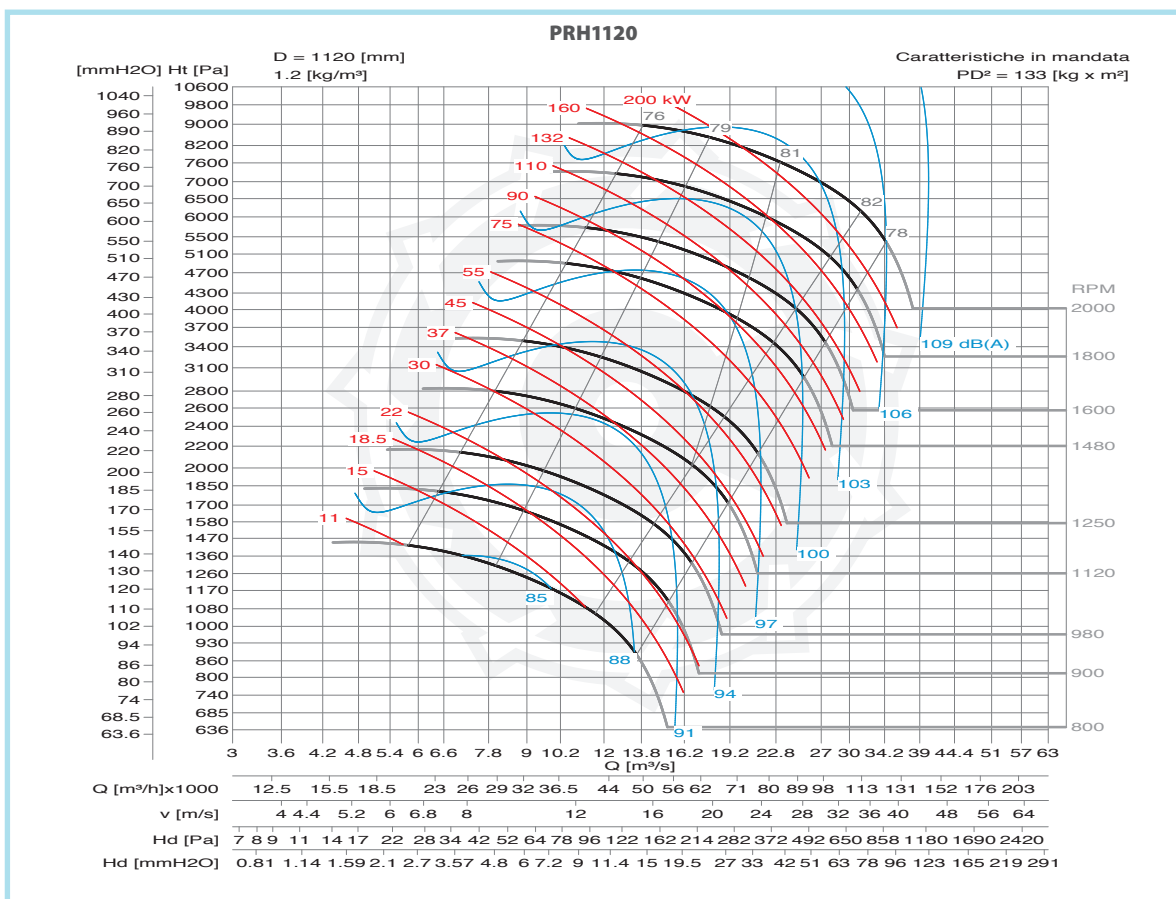
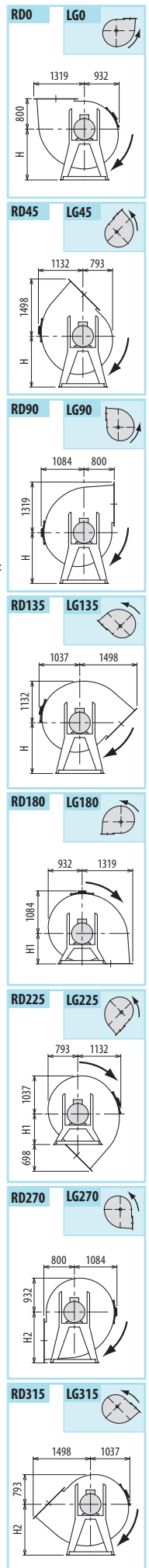
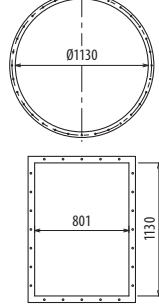

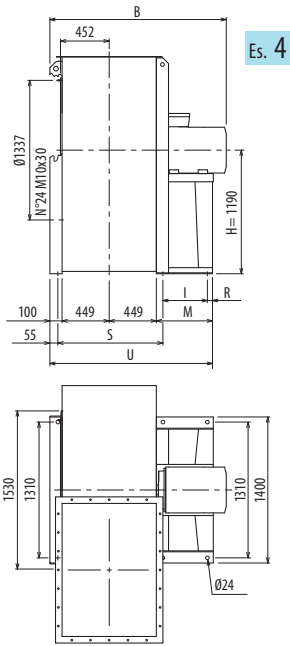

Es. 4

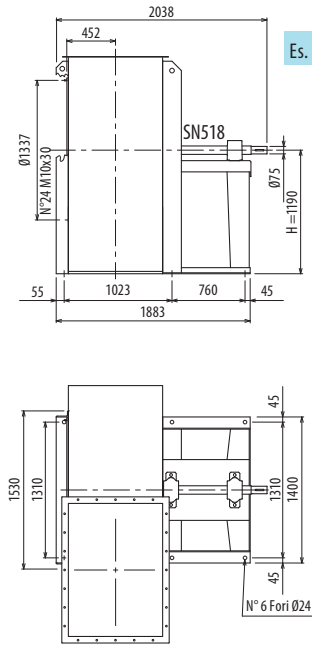

Es. 1

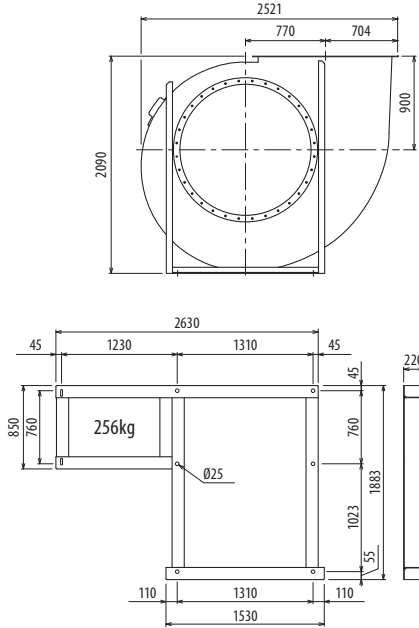

Il ventilatore non è orientabile • Peso in tabella comprensivo di motore

- Le ventilateur n'est pas orientable ■ The fan is not revolvable
- Der Ventilator ist nicht drehbar ■ El ventilador no es orientable
- Le poids dans le tableau inclut le moteur The weight indicated in the table includes motor Das Gewicht im Tafel schließt den Motor ein El peso en la tabla incluye el motor

Ulteriori informazioni e quote:
■ Ulérieures informations et cotes:
■ Further information and sizes:
■ Weitere Infos und Größen:
■ Más informaciones y medidas:

TIPO - Type		PESO Weight	PD²											
VENTILATORE Fan	MOTORE Motor	Kg	Kgf x m²	B	I	H	H1	H2	R	S	M	U		
PRH1250/4R	315 LA4	2110	209	2030	675	1190	900	1500	45	1023	800	1798		
PRH1250/4	315 LB4	2315	238	2030	675	1190	900	1500	45	1023	800	1798		
PRH1250/6R	280 S6	1699	209	1818	565	1190	900	1500	45	1023	690	1688		
PRH1250/6	280 M6	1739	238	1818	565	1190	900	1500	45	1023	690	1688		
PRH1250/T		1258	238			1190	900	1500						

pg. / S. 4,6
pg. / S. 4,5

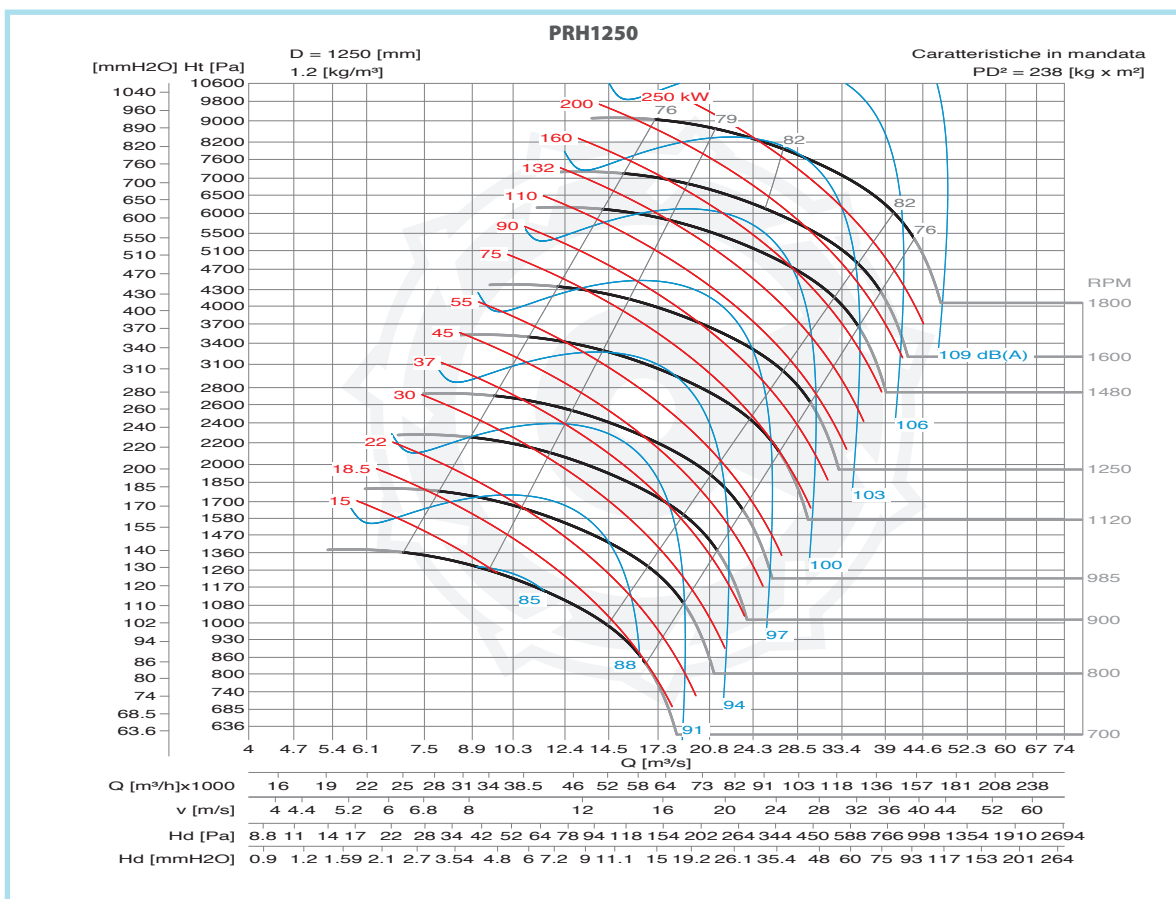
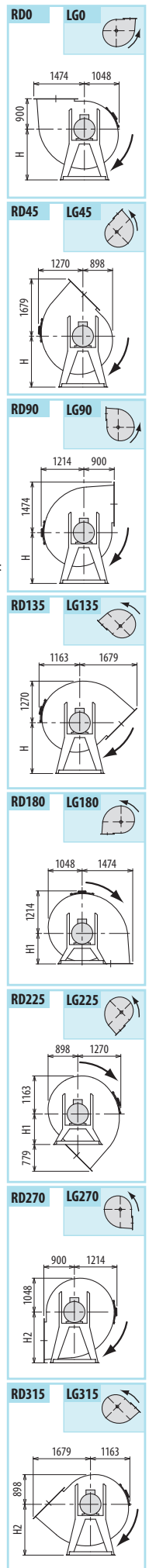
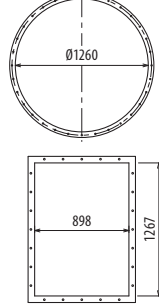

DIMENSIONI D'INGOMBRO E PESI/CURVE DI FUNZIONAMENTO

PRH1400



■ DIMENSIONS D'ENCOMBREMENT ET POIDS/COURBES DE FONCTIONNEMENT ■ OVERALL DIMENSIONS AND WEIGHT/WORKING CURVES
 ■ AUSMARE UND GEWICHTE/FUNKTIONSKURVEN ■ DIMENSIONES QUE OCUPA Y PESOS/CURVAS DE FUNCIONAMIENTO

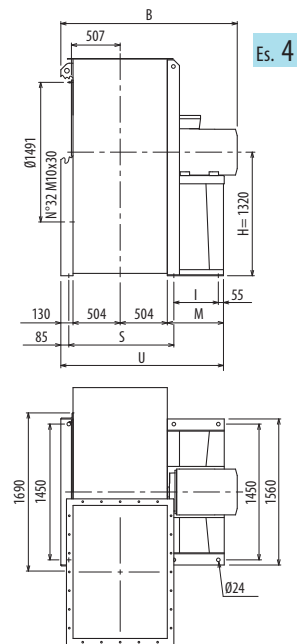

Es. 4

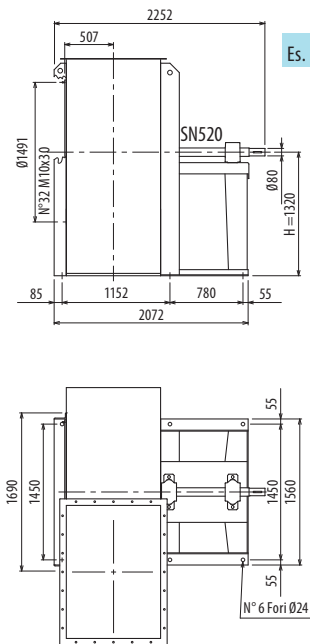

Es. 1

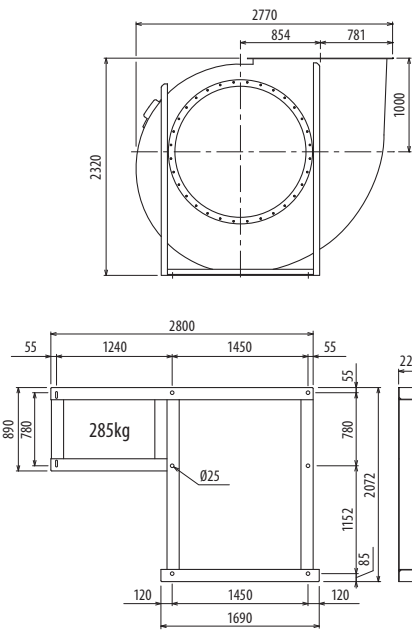

Il ventilatore non è orientabile - Peso in tabella comprensivo di motore

- Le ventilateur n'est pas orientable ■ The fan is not revolvable
- Der Ventilator ist nicht drehbar ■ El ventilador no es orientable
- Le poids dans le tableau inclut le moteur The weight indicated in the table includes motor Das Gewicht im Tafel schließt den Motor ein El peso en la tabla incluye el motor

Ulteriori informazioni e quote:
 ■ Ulteriori informazioni e cotes:
 ■ Further information and sizes:
 ■ Weitere Infos und Größen:
 ■ Más informaciones y medidas:

TIPO - Type		PESO Weight	PD ²												
VENTILATORE Fan	MOTORE Motor	Kg	Kgf x m ²	B	I	H	H1	H2	H3	H4	M	S	U		
PRH1400/4R	315 A4	2772	359	2330	645	1320	1000	1700	1320	1700	800	1152	1937		
PRH1400/4	315 B4	2777	376	2330	645	1320	1000	1700	1320	1700	800	1152	1937		
PRH1400/6R	315 S6	2362	359	2330	645	1320	1000	1700	1320	1700	800	1152	1937		
PRH1400/6	315 M6	2527	376	2330	645	1320	1000	1700	1320	1700	800	1152	1937		
PRH1400/T		1712	376			1320	1000	1700	1120	1500					

pg. / s. 4,6

pg. / s. 4,5

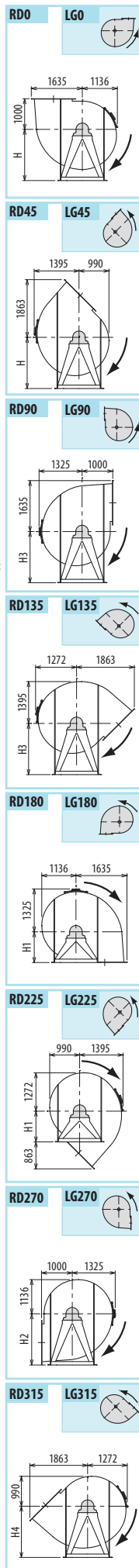
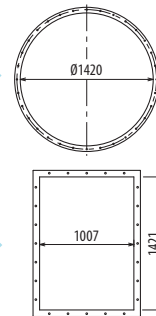

PRH

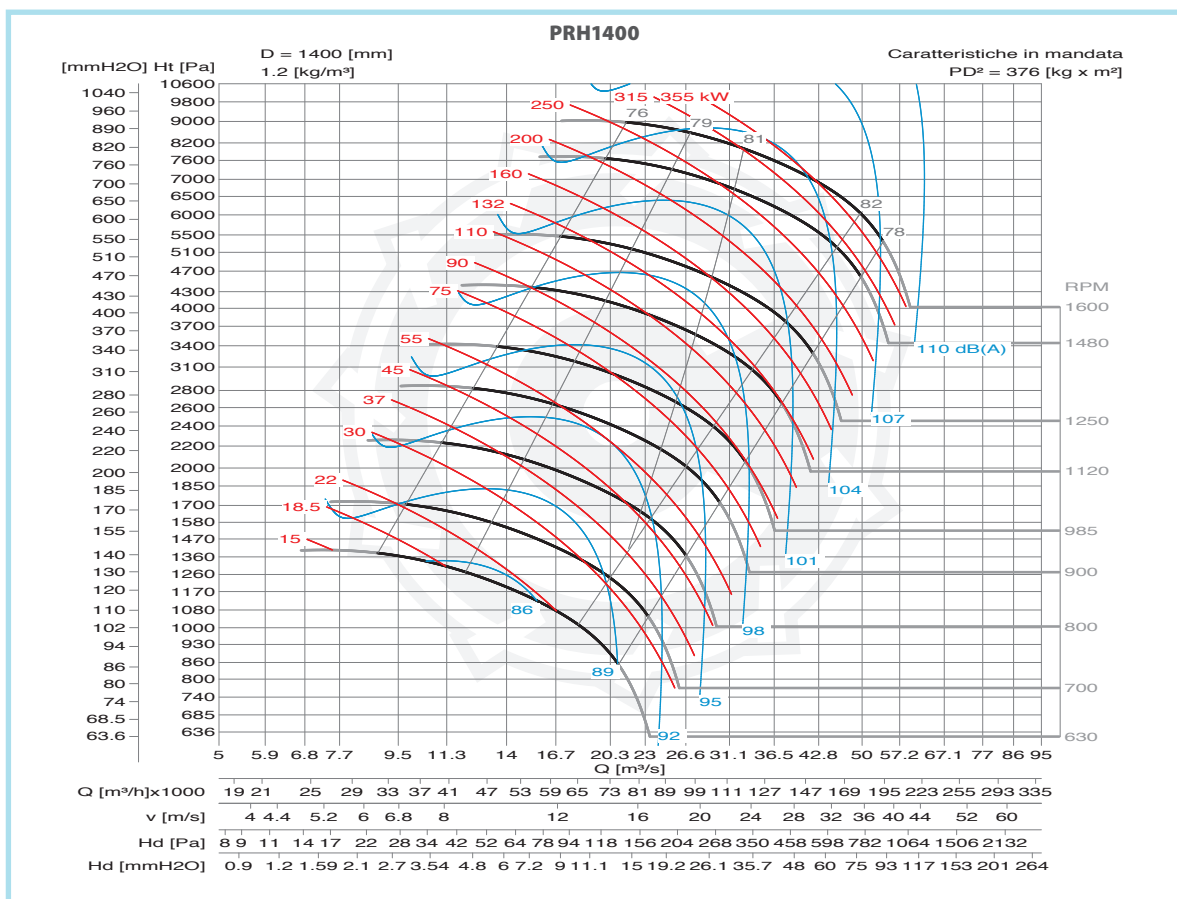

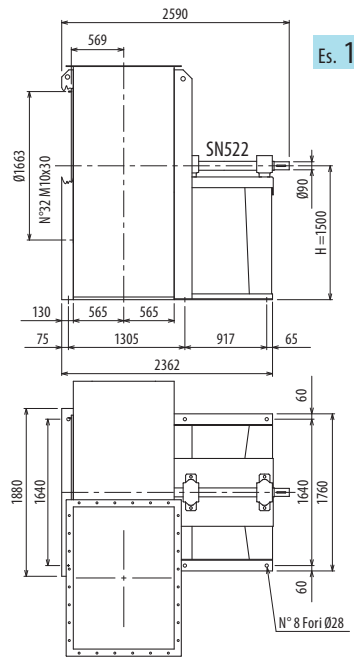

Es. 1

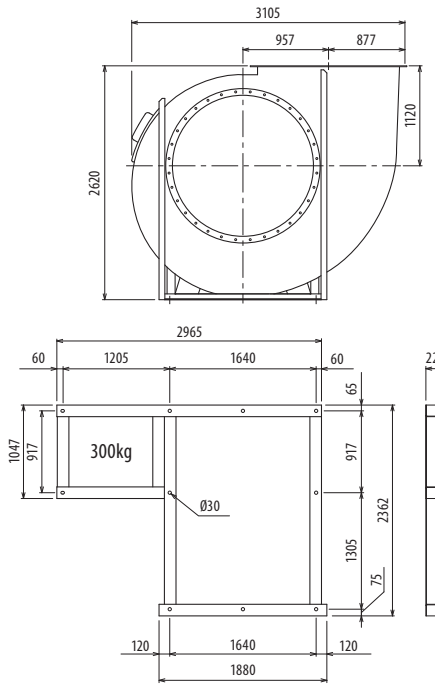

Ulteriori informazioni e quote:
■ Ulérieures informations et cotes:
■ Further information and sizes:
■ Weitere Infos und Größen:
■ Más informaciones y medidas:

Il ventilatore non è orientabile

■ Le ventilateur n'est pas orientable

■ The fan is not revolvable

■ Der Ventilator ist nicht drehbar

■ El ventilador no es orientable

TIPO - Type		PESO Weight Kg	PD ² Kg f x m ²	B	I	H	H1	H2	H3	H4	M
VENTILATORE Fan	MOTORE Motor										
PRH1600/T		2363	630			1500	1120	1900	1250	1600	

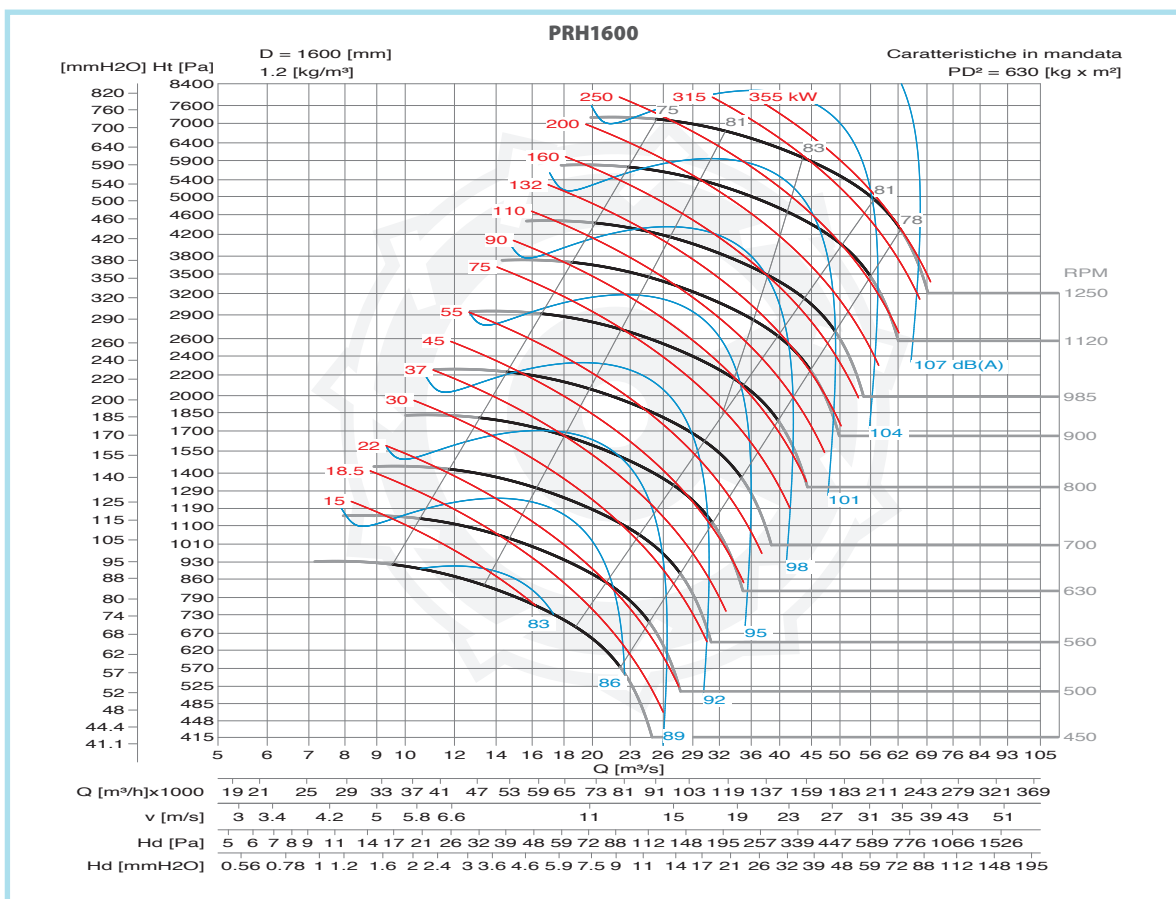
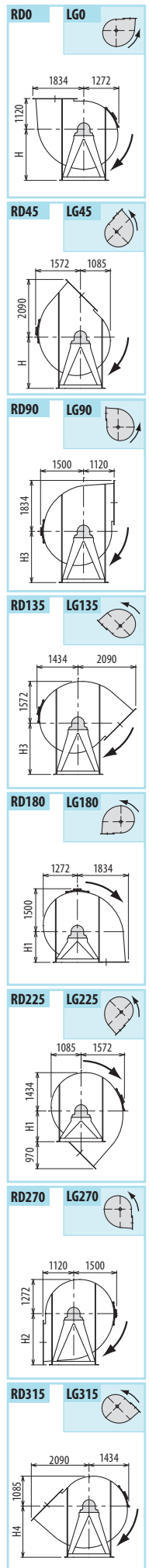
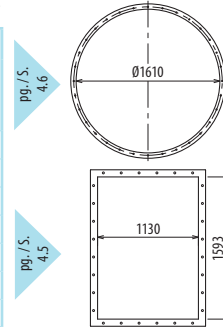

■ DIMENSIONS D'ENCOMBREMENT ET POIDS/COURBES DE FONCTIONNEMENT ■ OVERALL DIMENSIONS AND WEIGHT/WORKING CURVES
■ AUSMARE UND GEWICHTE/FUNKTIONSKURVEN ■ DIMENSIONES QUE OCUPA Y PESOS/CURVAS DE FUNCIONAMIENTO

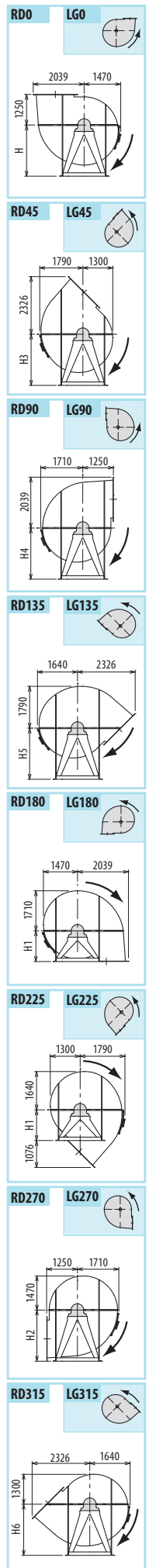
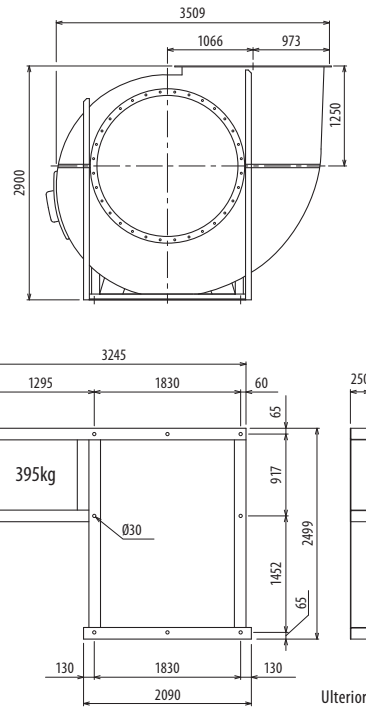
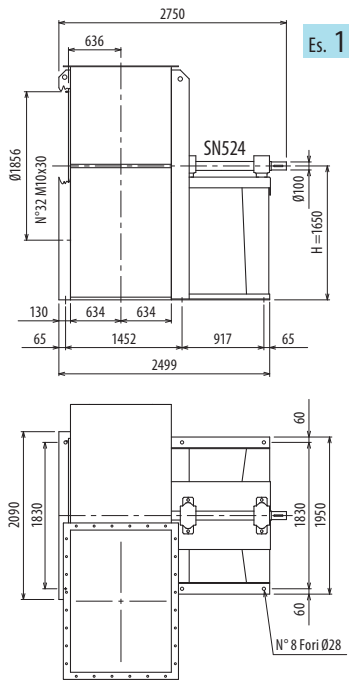

Il ventilatore non è orientabile

■ Le ventilateur n'est pas orientable ■ The fan is not revolvable ■ Der Ventilator ist nicht drehbar ■ El ventilador no es orientable

TIPO - Type		PESO Weight	PD ²											
VENTILATORE Fan	MOTORE Motor	Kg	Kgf x m ²	B	I	H	H1	H2	H3	H4	M	H6		
PRH1800/T		2912	1400			1650	1250	2120	1570	1400				pg. / s. 4,6

Ulteriori informazioni e quote:
■ Ulérieures informations et cotes:
■ Further information and sizes:
■ Weitere Infos und Größen:
■ Más informaciones y medidas:

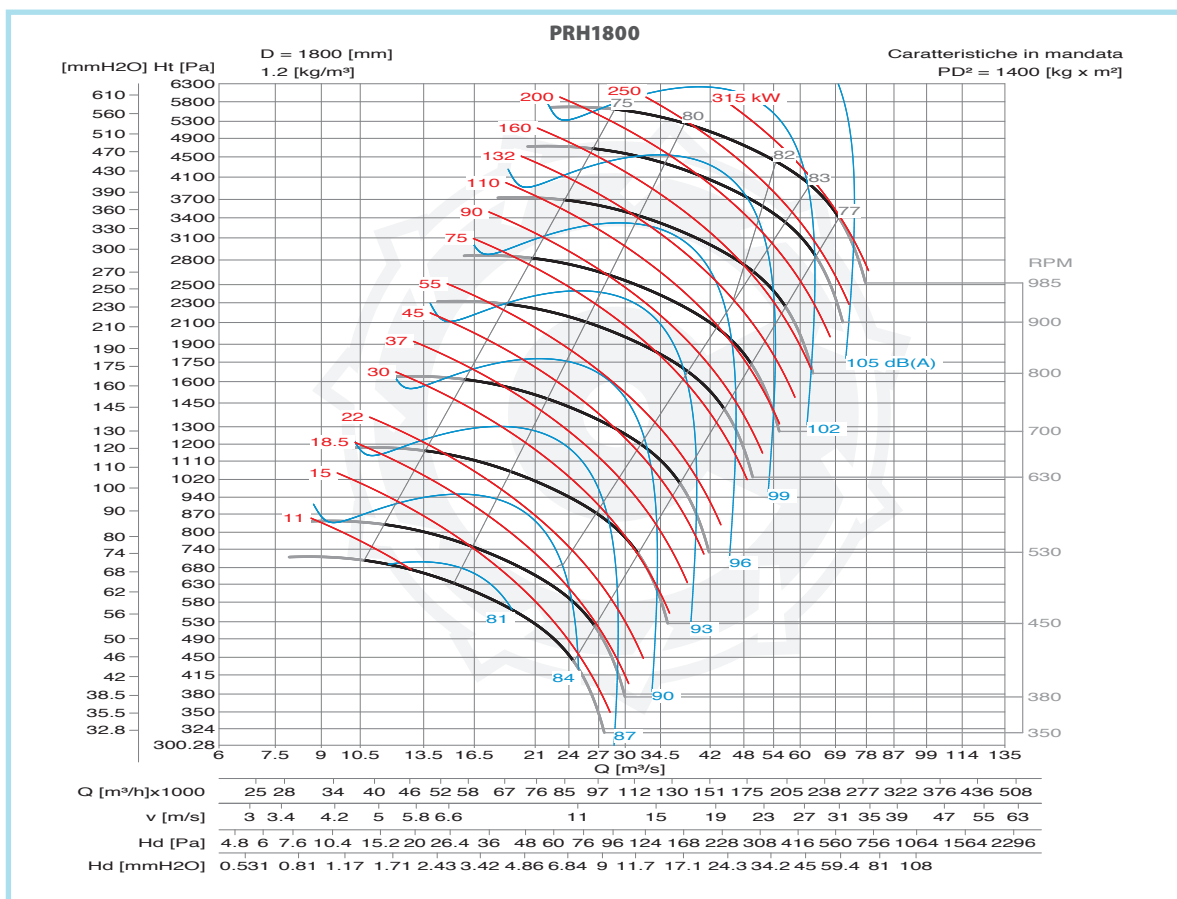
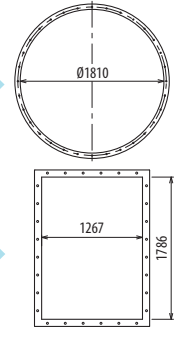

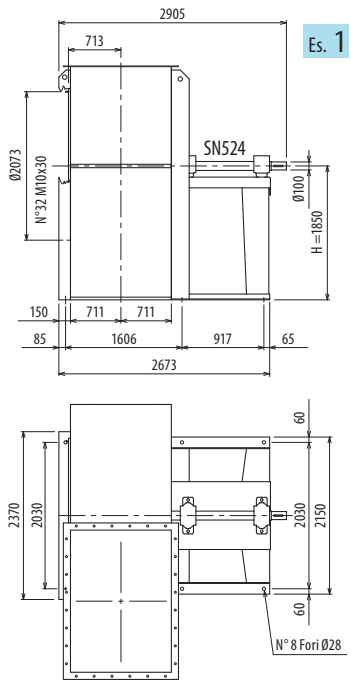

Es. 1

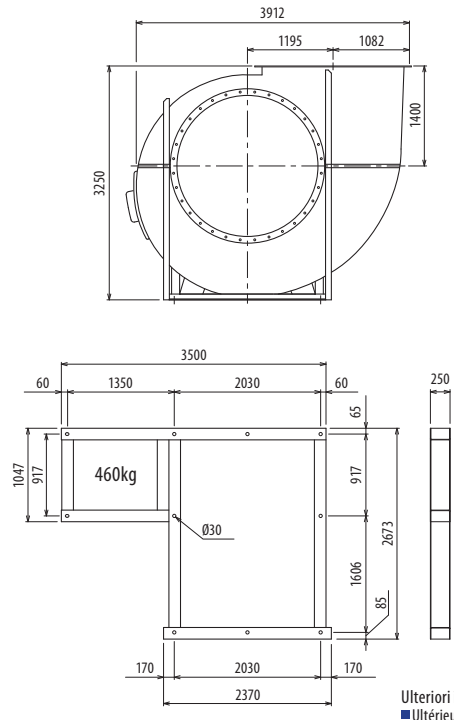

Ulteriori informazioni e quote:
 ■ Ulérieures informations et cotes:
 ■ Further information and sizes:
 ■ Weitere Infos und Größen:
 ■ Más informaciones y medidas:

Il ventilatore non è orientabile
 ■ Le ventilateur n'est pas orientable ■ The fan is not revolvable ■ Der Ventilator ist nicht drehbar ■ El ventilador no es orientable

TIPO - Type		PESO Weight Kg	PD ² Kg f x m ²	B	I	H	H1	H2	H3	H4	M	H6
VENTILATORE Fan	MOTORE Motor											
PRH2000/T		3413	2250			1850	1400	2360	1750	1600		

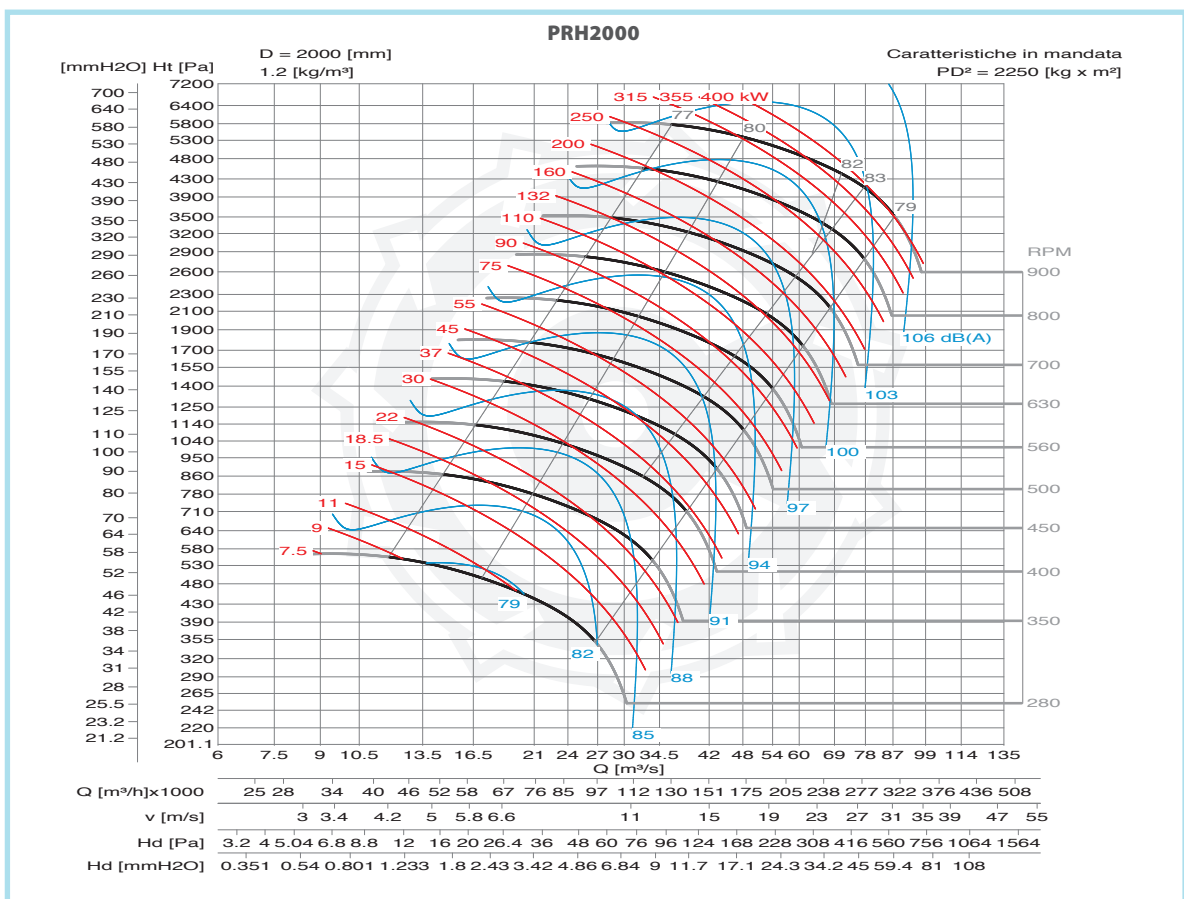
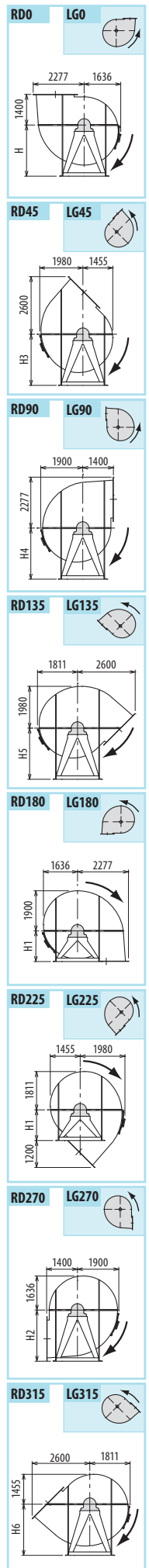
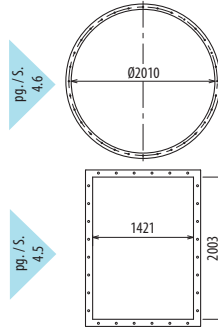



CORAL ENGINEERING SRL

Via Venezia 4/6 - 20060 Trezzano Rosa (MI) ITALY

• +39 02 95301003 - Fax +39 02 95301004

e-mail: info@coral.it <http://www.coral.it>

SOCIETÀ DI ENGINEERING - SOCIÉTÉS D'INGENIERIE - ENGINEERING SISTER COMPANIES - INGENIEURFIRMEN - SOCIEDADES DE INGENIERIA

ITALIA

MILANO • +39 02 95301003
TORINO • +39 011 9980141
VICENZA • +39 0444 348999

FRANCE

LYON • +33 4 74 944 562
PARIS • +33 1 60 868 069
POITIERS • +33 5 49 379 596

ENGLAND

LITTLEBOROUGH ROCHDALE • +44 1 706 373100