

Mod. **PDA**

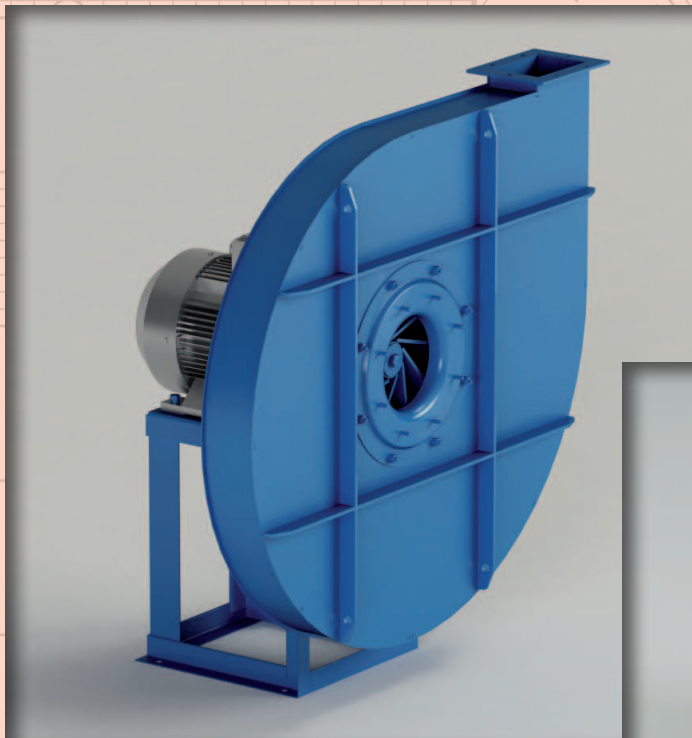

$Q = 180 \div 3600 \text{ m}^3/\text{h}$

$Q = 0.05 \div 1 \text{ m}^3/\text{s}$

$p_t = 140 \div 1000 \text{ mmH}_2\text{O}$

$p_t = 1400 \div 10000 \text{ Pa}$

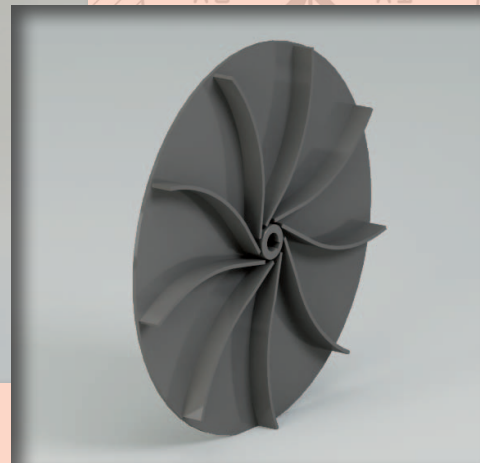

Campo di lavoro

Portate basse. Pressioni medio-alte.

Tipo di pala

Pale radiali curve, aperta.

Applicazioni

Per trasporto pneumatico, di materiali solidi in miscela con aria, segatura e trucioli di legno; anche per materiali filamentosi che ostruirebbero una ventola chiusa a pale rovesce.

Esecuzioni costruttive standard

Es.1-Es.4-Es.5-Es.8-Es.9-Es.12, vedi pag. 2.5-2-6.

Temperature del fluido standard

-10÷+60°C. Per altre temperature vedi da pag. 1.12 a pag. 1.15.

Tipo di costruzione

Ventilatore in lamiera di Fe360, girante in Fe360 equilibrata staticamente e dinamicamente. Per altri materiali vedi da pag. 1.12 a pag. 1.15.

Dati di funzionamento

Condizioni dell'aria all'aspirazione T=20°C, 0m.s.l.m. e p=1.205 kg/m³.

Rumorosità

Espressa in potenza sonora L_{wA} [dB(A)] rilevata in campo libero con ventilatore canalizzato, vedi da pag. 1.43 a pag. 1.49.

Orientamenti

N°8 RD (rotazione oraria vista lato trasmissione) e N°8 LG. Ventilatore in versione imbullonata orientabile per le taglie 400-630, con supporto anteriore e quindi non orientabile dalla grandezza 710 a trasmissione, sempre orientabile nei ventilatori direttamente accoppiati senza supporto anteriore. Vedi pag. 2.7.

Costruzioni speciali

Vedi da pag. 2.20 a pag. 2.30.

Avviamento ventilatore

L'avviamento deve avvenire con ventilatore parzializzato, in funzione dell'assorbimento massimo del ventilatore.

Classi giranti

La seguente tabella fa riferimento a condizioni di lavoro standard. In condizioni di esercizio gravose si consiglia di contattare il servizio clienti di CORAL per conoscere la tipologia di girante più idonea.

■ **Domaine de travail**

Faibles débits. Moyennes-hautes pressions.

Type d'ailette

Ailettes radiales courbées, ouverte.

Applications

Pour transport pneumatique, de matières solides en mélange dans l'air, de sciure et de copeaux de bois, également pour des matières filamenteuses qui obstrueraient une hélice fermée à ailettes inversées.

Configurations de constructions standard

Ex.1 - Ex.4 - Ex.5 - Ex.8 - Ex.9 - Ex.12, voir pages 2.5-2-6.

Températures du fluide standard

-10÷+60°C. Pour d'autres températures voir pages 1.12-1.15.

Type de fabrication

Ventilateur en tôle de Fe360, turbine en Fe360 équilibrée statiquement et dynamiquement. Pour d'autres matériaux, voir pages 1.12-1.15.

Données de fonctionnement

Conditions de l'air à l'aspiration T=20°C, 0 m asl et p=1.205 kg/m³.

Niveau sonore

Exprimé en puissance sonore L_{wA} [dB(A)], relevé à l'air libre avec un ventilateur canalisé, voir pages 1.43 - 1.49.

Orientations

8 RD (rotation dans le sens des aiguilles d'une montre côté transmission) et 8 LG. Ventilateur en version boulonnée orientable pour les tailles 400-630, avec un support avant et donc non orientable de la grandeur 710 à transmission, toujours orientable dans les ventilateurs directement accouplés sans support avant. Voir page 2.7.

Fabrications spéciales

Voir pages 2.20-2.30.

Mise en marche du ventilateur

Le démarrage doit se faire avec un ventilateur partialisé, en fonction de l'absorption maximale du ventilateur.

Classes de turbines

Le tableau ci-dessus fait référence aux conditions de travail normales, en conditions de travail pénibles, on préconise de contacter le service clientèle de CORAL pour connaître le type de turbine le plus adapté.

GRANDEZZA PDA VENTILATORE • Grandeur • Size • Größe • Tamaño	RPM MASSIMO • Maxi tours/min. • Max rpm • Max. U/min • R.p.m. máx.
	CLASSE I
PDA400	5300
PDA450	4750
PDA500	4250
PDA560	3750
PDA630	3350
PDA710	3000
PDA800	2950
PDA900	2350
PDA1000	2100

VALORI VALIDI FINO A 60°C

• Valeurs valables jusqu'à 60°C • Values valid up to 60°C
• Werte bis 60°C gültig • Valores válidos hasta 60°C

FRA • entre • between • zwischen • entre	60°C	E • et • and • und • y	100°C	DECLASSARE VELOCITÀ • déclasser vitesse • degrade speed • Geschwindigkeit herabsetzen • rebajar velocidad	4%
	100°C		150°C		10%
	150°C		200°C		16%
	200°C		250°C		23%
	250°C		300°C		30%
	300°C		350°C		37%
	350°C		400°C		45%
	400°C		450°C		54%
	450°C		500°C		64%

■ **Field of operation**

Low flow rates. Medium-high pressures.

Blade type

Curved radial blades, open.

Applications

For pneumatic transport of solid materials mixed with air, sawdust and wood chips; also suitable for filaments which would block a reversed blade closed fan.

Standard constructional arrangements

Arr.1 - Arr.4 - Arr.5 - Arr.8 - Arr.9 - Arr.12, see pgs. 2.5-2-6.

Standard fluid temperatures

-10÷+60°C. For other temperatures see pgs. 1.12 to 1.15.

Type of construction

Fan in Fe360 plate, impeller in Fe360 statically and dynamically balanced. For other materials see pgs. 1.12 to 1.15.

Operating specifications

Condition of inlet air T=20°C, 0 m above sea level and p=1.205 kg/m³.

Noise level

Expressed as sound power L_{wA} [dB(A)] measured in free field with ducted fan, see pgs. 1.43 to 1.49.

Orientations

No.8 RD (clockwise viewed from transmission side) and No.8 LG. Fan in bolted orientable version for sizes 400-630, with front support and so not orientable for sizes 710 and above with transmission drive, always orientable for directly coupled fans without front support. See pg. 2.7.

Special applications

See pgs. 2.20 to 2.30.

Fan start-up

During start-up the fan flow rate must be limited, calibrated for the fan's maximum electrical input.

Impeller classes

The above table refers to standard operating conditions, in heavy-duty service conditions it is advisable to contact the CORAL Customer Service to establish the most suitable type of impeller.

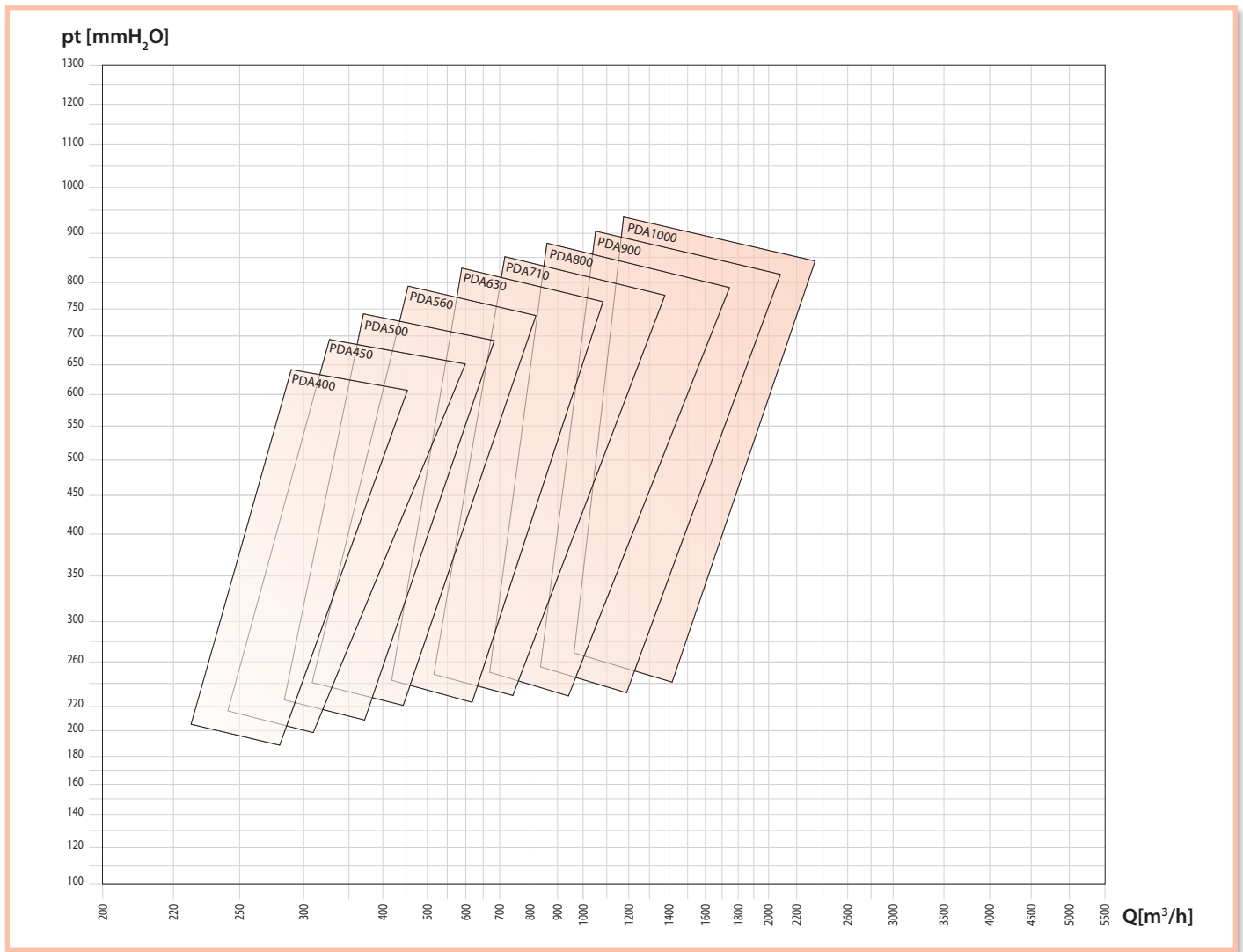

PDA

Arbeitsbereich

Niedrige Fördermengen. Mittlere - hohe Drücke.

Schaufelform

Gekrümmte Radialschaufeln, offen.

Anwendungen

Zum Transport von in Luft vermischten Feststoffen, Sägestaub und Holzspäne, auch für fadenförmige Materialien, die einen geschlossenen Ventilator mit rückwärts gekrümmten Schaufeln zusetzen würden.

Konstruktive Standardausführungen

Ausf. 1-Ausf. 4-Ausf. 5-Ausf. 8-Ausf. 9-Ausf. 12, siehe Seiten 2.5-2-6.

Standardtemperatur des Mediums

-10 ÷ +60°C. Für andere Temperaturen siehe Seiten 1.12 bis 1.15.

Konstruktionsart

Ventilator aus Blech Fe360, Laufrad aus Fe360, statisch und dynamisch ausgewuchtet. Für andere Materialien siehe Seiten 1.12 bis 1.15.

Betriebsdaten

Physikalischer Zustand der Ansaugluft T = 20°C, 0 m ü. M. und ρ = 1.205 kg/m³.

Geräuschpegel

angegeben als Schalleistungspegel L_{WA} [dB(A)] mit Messung im Freifeld und an Rohren angeschlossenem Ventilatore, siehe Seiten 1.43 bis 1.49.

Ausrichtung

8 Modelle RD (Drehrichtung im Uhrzeigersinn, von Antriebsseite aus gesehen) und 8 Modelle LG. Angeschraubter, in der Ausrichtung veränderbarer Ventilator in den Größen 400 - 630, mit Vorderstütze und damit nicht veränderbar ab Größe 710 mit Riementrieb, immer ausrichtbar bei allen direkt angetriebenen Ventilatoren ohne Vorderstütze, siehe Seite 2.7.

Spezialausführungen

Siehe Seiten 2.20 bis 2.30.

Ventilator-Anlauf

Der Ventilatoranlauf muss bei teilweise geschlossenem Ventilator erfolgen, in Abhängigkeit von der maximalen Stromaufnahme des Motors.

Laufradklassen

Die obenstehende Tabelle bezieht sich auf normale Betriebsbedingungen. Bei erschwerenden Betriebsbedingungen wird empfohlen, den Kundenservice von CORAL zu kontaktieren, um den am besten geeigneten Laufradtyp zu bestimmen.

Campo de trabajo

Caudales bajos. Presiones medio-altas.

Tipo de pala

Palas radiales curvas, abierta.

Aplicaciones

Para transporte neumático de materiales sólidos mezclados con aire, serrín y virutas de madera; también para materiales filamentosos que obstruirían un ventilador cerrado de palas invertidas.

Variantes constructivas estándares

Ejec. 1-Ejec. 4-Ejec. 5-Ejec. 8-Ejec. 9-Ejec. 12, ver págs. 2.5-2-6.

Temperaturas del fluido estándares

De -10 a +60°C. Para otras temperaturas, ver págs. de 1.12 a 1.15.

Tipo de construcción

Ventilador de chapa en Fe360, rotor en Fe360 equilibrado estática y dinámicamente. Para otros materiales, ver págs. de 1.12 a 1.15.

Datos de funcionamiento

Condiciones del aire en aspiración T = 20°C, 0 m SNM y ρ = 1.205 kg/m³.

Niveles de ruido

Expresados en potencia sonora L_{WA} [dB(A)] medida en campo abierto con ventilador canalizado, ver págs. de 1.43 a 1.49.

Orientaciones

8 RD (rotación dextrógira vista desde el lado de transmisión) y 8 LG. Ventilador en versión empernada orientable para tamaños 400-630, con soporte delantero, por lo cual no es orientable a partir del tamaño 710 de transmisión, siempre orientable en ventiladores acoplados directamente sin soporte delantero. Ver pág. 2.7.

Construcciones especiales

Ver págs. de 2.20 a 2.30.

Puesta en marcha del ventilador

La puesta en marcha debe efectuarse con ventilador parcializado, en función de la absorción máxima del ventilador.

Clases de rotores

La tabla arriba hace referencia a condiciones de trabajo estándares, en condiciones de funcionamiento pesadas se aconseja llamar al Servicio de atención al cliente de CORAL para conocer el tipo de rotor más adecuado.

Tipo • Type • Type • Typ • Tipo		P inst. [kW]	n	LpA [dB(A)]	Tolleranza sulla portata ±5% • Tolérance sur le débit ±5% • Load tolerance ±5% • Durchsatztoleranz ±5% • Tolerancia respecto caudal ±5%											
Ventilatore • Ventilateur • Fan • Ventilator • Ventilador	Motore • Moteur • Motor • Motor • Motor				Q [m³/h]											
					145	180	215	250	290	325	360	400	430	470	540	
					pt[mmH ₂ O]											
PDA400/P2	80	0,75	2820	57	252	250	248	246	242	238	232	229	224			
PDA400/P2	80	1,1	2845	58	257	255	253	251	248	243	237	234	229	222		
PDA450/P2	80	1,1	2845	61			333	330	327	323	319	314	309	304	298	
PDA450/P2	90	1,5	2870	62			338	335	332	328	324	319	314	309	303	
PDA500/P2	90	2,2	2900	64					425	422	420	418	416	413	406	
PDA500/P2	100	3	2940	65					440	437	435	433	431	428	421	
PDA560/P2	100	3	2940	69								547	546	545	543	
PDA560/P2	112	4	2950	70								552	551	549	547	
PDA630/P2	132	5,5	2950	74											682	
PDA630/P2	132	7,5	2950	76											682	
PDA710/P2	132	7,5	2950	76												
PDA710/P2	160	11	2955	78												
PDA800/P2R	160	15	2960	78												
PDA800/P2	160	18,5	2960	80												
PDA800/P4R	100	3	1420	61										235	233	
PDA800/P4	112	4	1440	63											263	
PDA900/P4R	132	5,5	1455	67												
PDA900/P4	132	7,5	1460	68												
PDA1000/P4R	132	7,5	1460	69												
PDA1000/P4	160	11	1460	70												

PDA
CARATTERISTICHE IN ASPIRAZIONE

Tipo • Type • Type • Typ • Tipo		P inst. [kW]	n	LpA [dB(A)]	Tolleranza sulla portata ±5% • Tolérance sur le débit ±5% • Load tolerance ±5% • Durchsatztoleranz ±5% • Tolerancia respecto caudal ±5%											
Ventilatore • Ventilateur • Fan • Ventilator • Ventilador	Motore • Moteur • Motor • Motor • Motor				Q [m³/h]											
					145	180	215	250	290	325	360	400	430	470	540	
					pt[mmH ₂ O]											
PDA400/P2	80	0,75	2820	57	244	241	238	235	229	224	216	211	204			
PDA400/P2	80	1,1	2845	58	249	246	243	240	235	229	221	215	209	199		
PDA450/P2	80	1,1	2845	61			320	316	312	308	302	296	290	283	274	
PDA450/P2	90	1,5	2870	62			325	321	317	312	307	301	295	288	277	
PDA500/P2	90	2,2	2900	64					405	402	399	396	394	389	381	
PDA500/P2	100	3	2940	65					419	416	413	410	407	403	393	
PDA560/P2	100	3	2940	69								516	515	513	510	
PDA560/P2	112	4	2950	70								521	519	517	513	
PDA630/P2	132	5,5	2950	74											636	
PDA630/P2	132	7,5	2950	76											635	
PDA710/P2	132	7,5	2950	76												
PDA710/P2	160	11	2955	78												
PDA800/P2R	160	15	2960	78												
PDA800/P2	160	18,5	2960	80												
PDA800/P4R	100	3	1420	61										228	226	
PDA800/P4	112	4	1440	63											255	
PDA900/P4R	132	5,5	1455	67												
PDA900/P4	132	7,5	1460	68												
PDA1000/P4R	132	7,5	1460	69												
PDA1000/P4	160	11	1460	70												

Il livello di pressione sonora ponderato A, LpA (cap.14), corrisponde al valore rilevato, nelle condizioni di prova, nel punto di massima rumorosità.

Tolleranza sulla rumorosità ±4dB(A)															
• Tolérance sur le bruit ±4dB(A) • Noise tolerance ±4dB(A)															
• Geräushtoleranz ±4dB(A) • Tolerancia respecto a ruido ±4dB(A)															
Q [m³/h]															
650	720	790	865	935	1080	1225	1370	1440	1620	1800	2160	2520	2880	3240	4000
pt[mmH ₂ O]															
285															
397	387	377	366												
412	402	392	381												
536	531	525	519	512											
541	536	530	524	517	500	485									
678	672	668	660	654	644	632	616	600							
678	672	668	660	654	644	632	616	600	582	555					
	858	858	858	856	852	846									
		860	860	860	857	852	843	836	830	805	765	705			
					1030	1025	1015	1010	1000	990	960	920			
					1106	1100	1095	1090	1085	1080	1060	1025	990		
232	231	228	225	224	221	216	208	198	190	175					
260	258	255	252	250	247	240	233	228	222	210					
	318	316	314	312	310	308	301	294	288	281	265	240			
		340	339	336	334	332	330	326	320	316	300	285	260		
					390	386	382	378	374	368	362	346	326	304	
					420	419	416	412	408	404	400	390	370	350	310

PDA

CARATTERISTICHE IN ASPIRAZIONE

Tolleranza sulla rumorosità ±4dB(A)															
• Tolérance sur le bruit ±4dB(A) • Noise tolerance ±4dB(A)															
• Geräushtoleranz ±4dB(A) • Tolerancia respecto a ruido ±4dB(A)															
Q [m³/h]															
650	720	790	865	935	1080	1225	1370	1440	1620	1800	2160	2520	2880	3240	4000
pt[mmH ₂ O]															
254															
368	355	342	327												
382	369	356	341												
500	494	486	478	469											
505	498	491	483	473	452	430									
630	624	619	610	603	590	575	555	538							
630	624	619	610	603	590	575	555	538	514	481					
	788	787	786	784	778	770									
		789	788	787	782	775	764	757	747	720	674	607			
					931	925	915	910	899	887	855	812			
					993	987	981	976	969	962	938	901	862		
224	223	219	216	214	209	203	193	182	171	152					
251	249	245	242	239	234	226	217	211	201	186					
	307	304	302	300	297	294	286	278	271	262	241	211			
		327	326	322	319	316	313	308	301	295	274	254	223		
					373	369	364	360	355	348	339	320	297	271	
					401	399	396	391	386	381	374	361	338	314	263

■ Le niveau de pression sonore pondérée A, LpA (chap. 14), correspond à la valeur relevée dans les conditions d'essai au point de niveau sonore maximum.

■ Der nach A bewertete Schalldruckpegel LpA (Kap. 14) entspricht in den Testbedingungen dem höchsten gemessenen Wert des Geräuschpegels.

■ The A-weighted sound power level, LpA (Chap.14), is the value measured in test conditions at the point of maximum noise level.

■ El nivel de presión sonora ponderado A, LpA (cap. 14), corresponde al valor medido, en las condiciones de prueba, en el punto con máximos niveles de ruido.

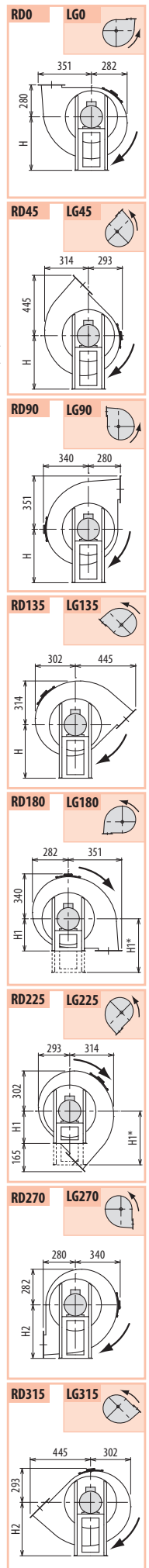
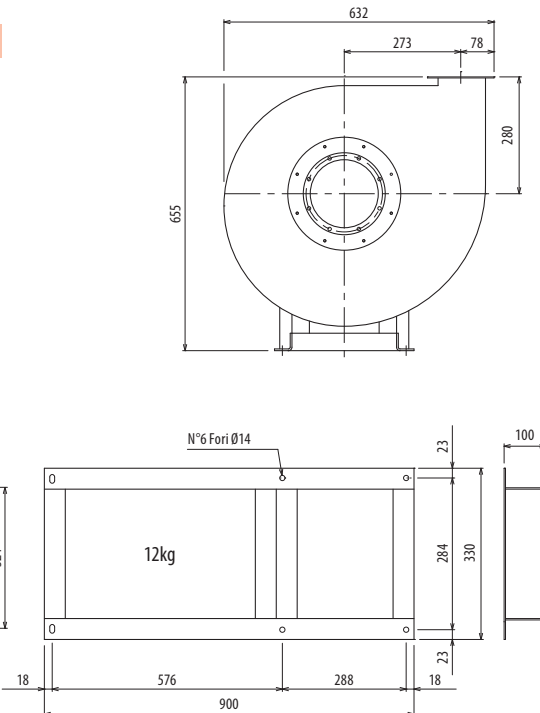
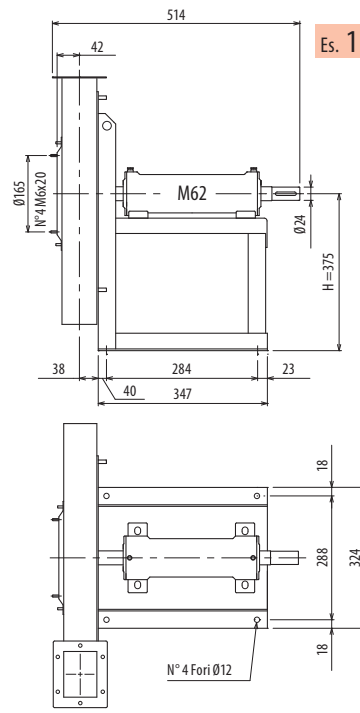
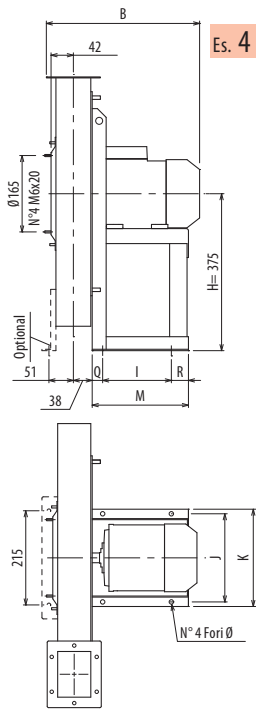

Il ventilatore è orientabile • Peso in tabella comprensivo di motore

- Le ventilateur est orientable
- The fan is revolvable
- Der Ventilator ist drehbar
- El ventilador es orientable
- Le poids dans le tableau inclut le moteur
- The weight indicated in the table includes motor
- Das Gewicht in Tafel schließt den Motor ein
- El peso en la tabla incluye el motor

Ulteriori informazioni e quote:
■ Ulérieures informations et cotes:
■ Further information and sizes:
■ Weitere Infos und Größen:
■ Más informaciones y medidas:

TIPO - Type		PESO Weight	PD ²	B	I	H	H1	H2	J	K	M	Q	R	Ø
VENTILATORE Fan	MOTORE Motor	Kg	Kgf x m ²											
PDA400/P2	80 A2	39	0,4	336	121	375	375*	375	203	225	211	45	45	10
PDA400/P2	80 B2	39	0,4	336	121	375	375*	375	203	225	211	45	45	10
PDA400/P/T		37	0,4			375	280	375						

pg. / s. 4,6
pg. / s. 4,5

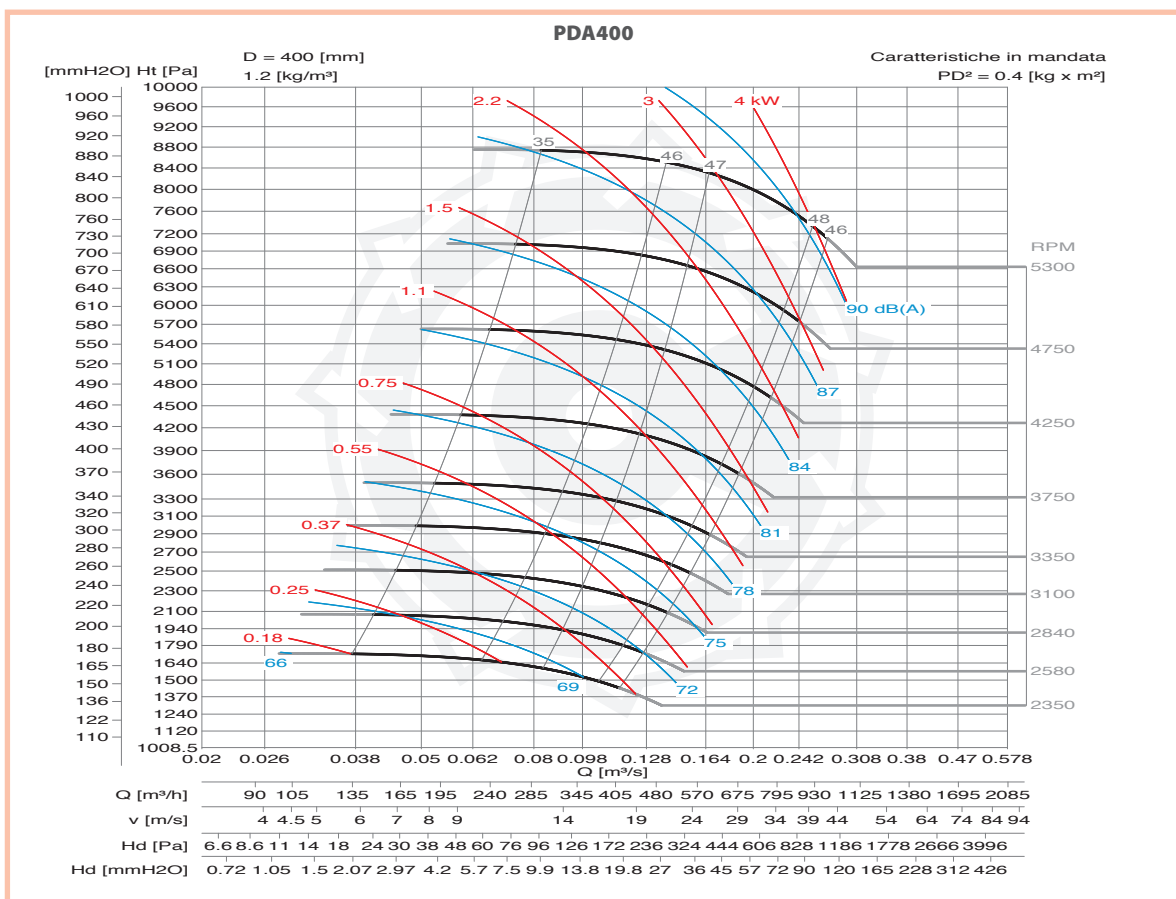
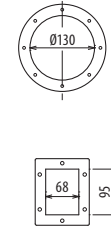

DIMENSIONI D'INGOMBRO E PESI/CURVE DI FUNZIONAMENTO

■ DIMENSIONS D'ENCOMBREMENT ET POIDS/COURBES DE FONCTIONNEMENT ■ OVERALL DIMENSIONS AND WEIGHT/WORKING CURVES
 ■ AUSMAßE UND GEWICHTE/FUNKTIONSKURVEN ■ DIMENSIONES QUE OCUPA Y PESOS/CURVAS DE FUNCIONAMIENTO

PDA450/P

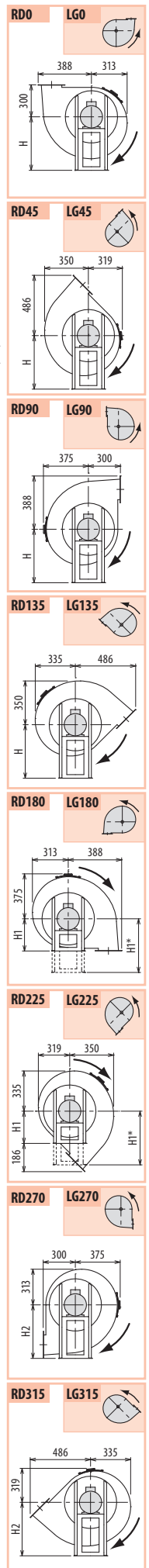
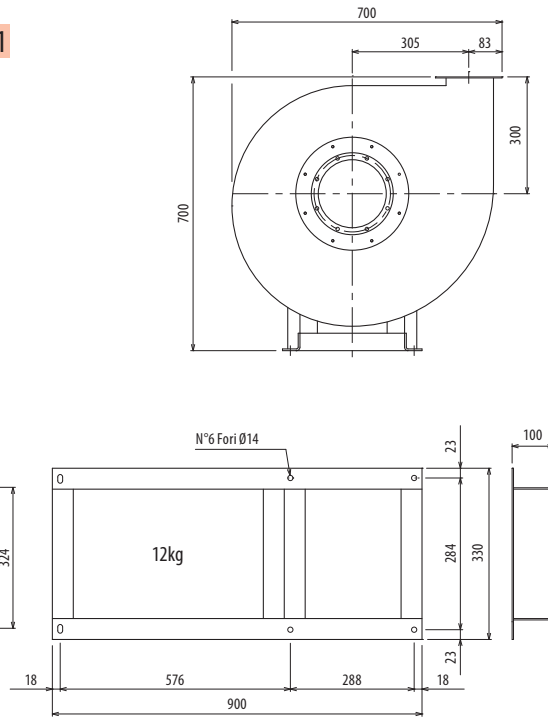
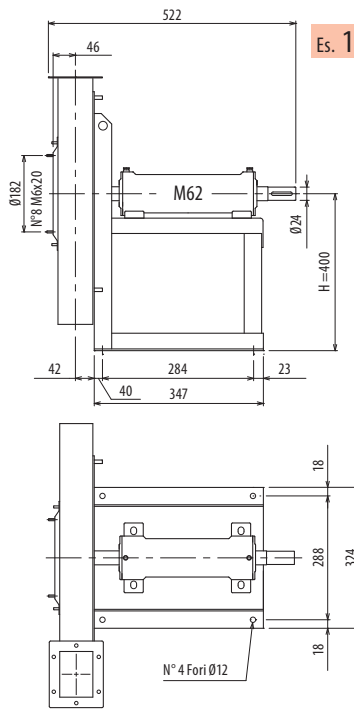
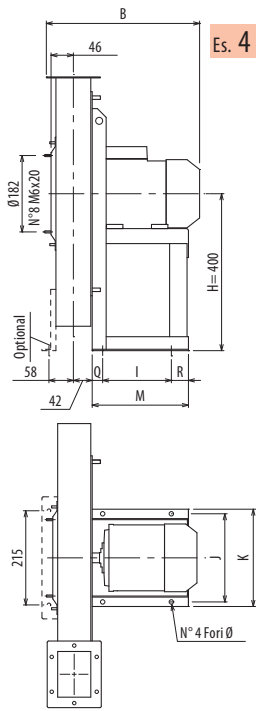

Il ventilatore è orientabile • Peso in tabella comprensivo di motore

- Le ventilateur est orientable
- The fan is revolvable
- Der Ventilator ist drehbar
- El ventilador es orientable
- Further information and sizes:
- Weitere Infos und Größen:
- Más informaciones y medidas:

Ulteriori informazioni e quote:
 ■ Ulérieures informations et cotes:
 ■ Further information and sizes:
 ■ Weitere Infos und Größen:
 ■ Más informaciones y medidas:

TIPO - Type		PESO Weight	PD²											
VENTILATORE Fan	MOTORE Motor	Kg	Kgf x m²	B	I	H	H1	H2	J	K	M	Q	R	Ø
PDA450/P2	80 B2	42	0,8	344	121	400	400*	400	203	225	211	45	45	10
PDA450/P2	90 S2	45	0,8	391	133	400	400*	400	234	260	246	55	58	10
PDA450/P/T		48	0,8			400	300	400						

pg. / s. 4,6
 pg. / s. 4,5

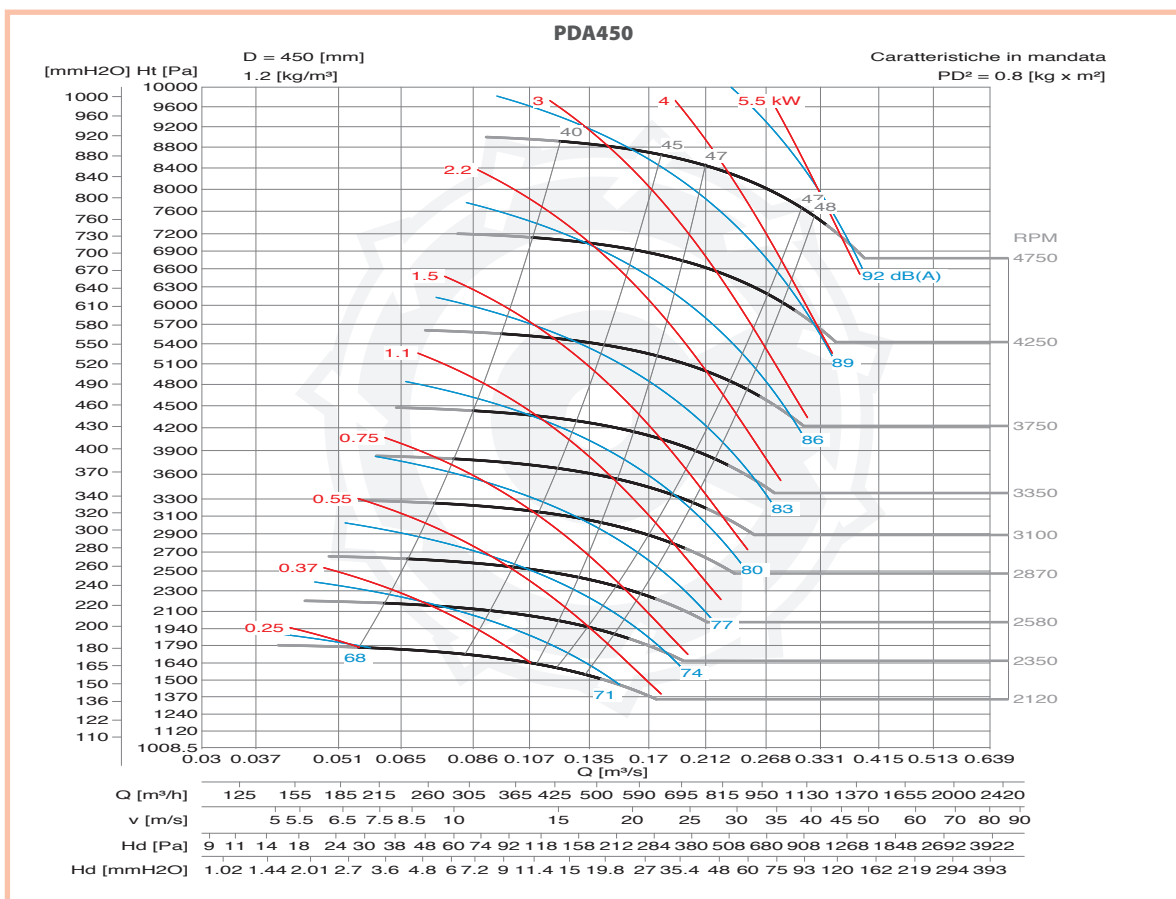
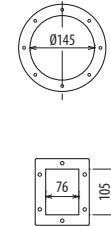

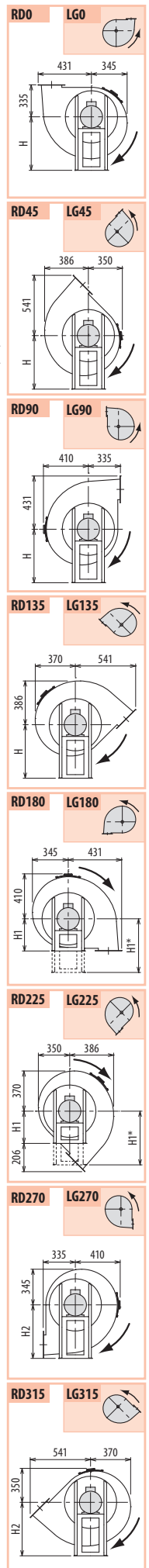
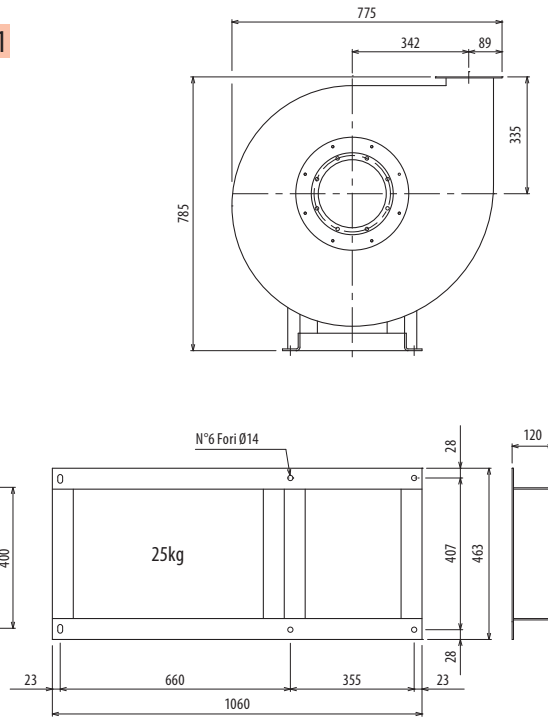
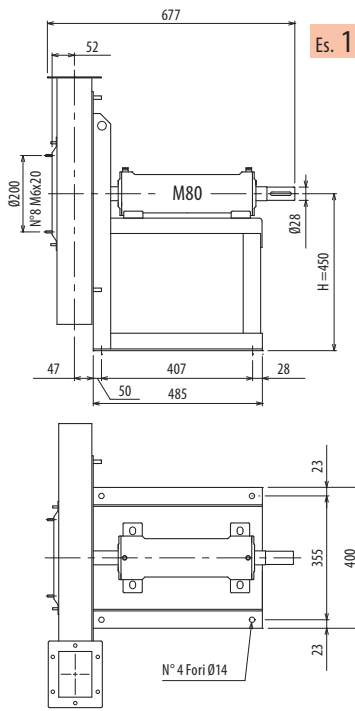
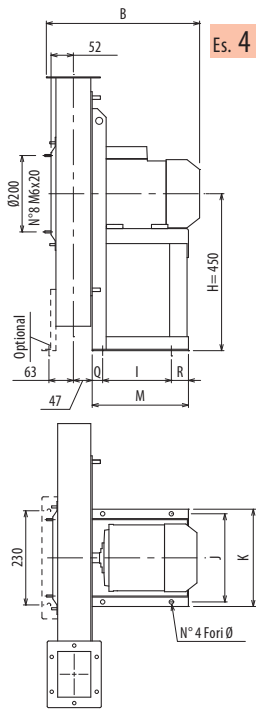

Il ventilatore è orientabile • Peso in tabella comprensivo di motore

- Le ventilateur est orientable
- The fan is revolvable
- Der Ventilator ist drehbar
- El ventilador es orientable
- Le poids dans le tableau inclut le moteur
- The weight indicated in the table includes motor
- Das Gewicht in Tafel schließt den Motor ein
- El peso en la tabla incluye el motor

Ulteriori informazioni e quote:
■ Ulérieures informations et cotes:
■ Further information and sizes:
■ Weitere Infos und Größen:
■ Más informaciones y medidas:

TIPO - Type		PESO Weight	PD ²											
VENTILATORE Fan	MOTORE Motor	Kg	Kgf x m ²	B	I	H	H1	H2	J	K	M	Q	R	Ø
PDA500/P2	90 L2	55	1,2	400	133	450	450*	450	234	260	246	55	58	10
PDA500/P2	100 L2	63	1,2	431	197	450	450*	450	289	324	276	30	49	12
PDA500/P/T		68	1,2			450	335	450						

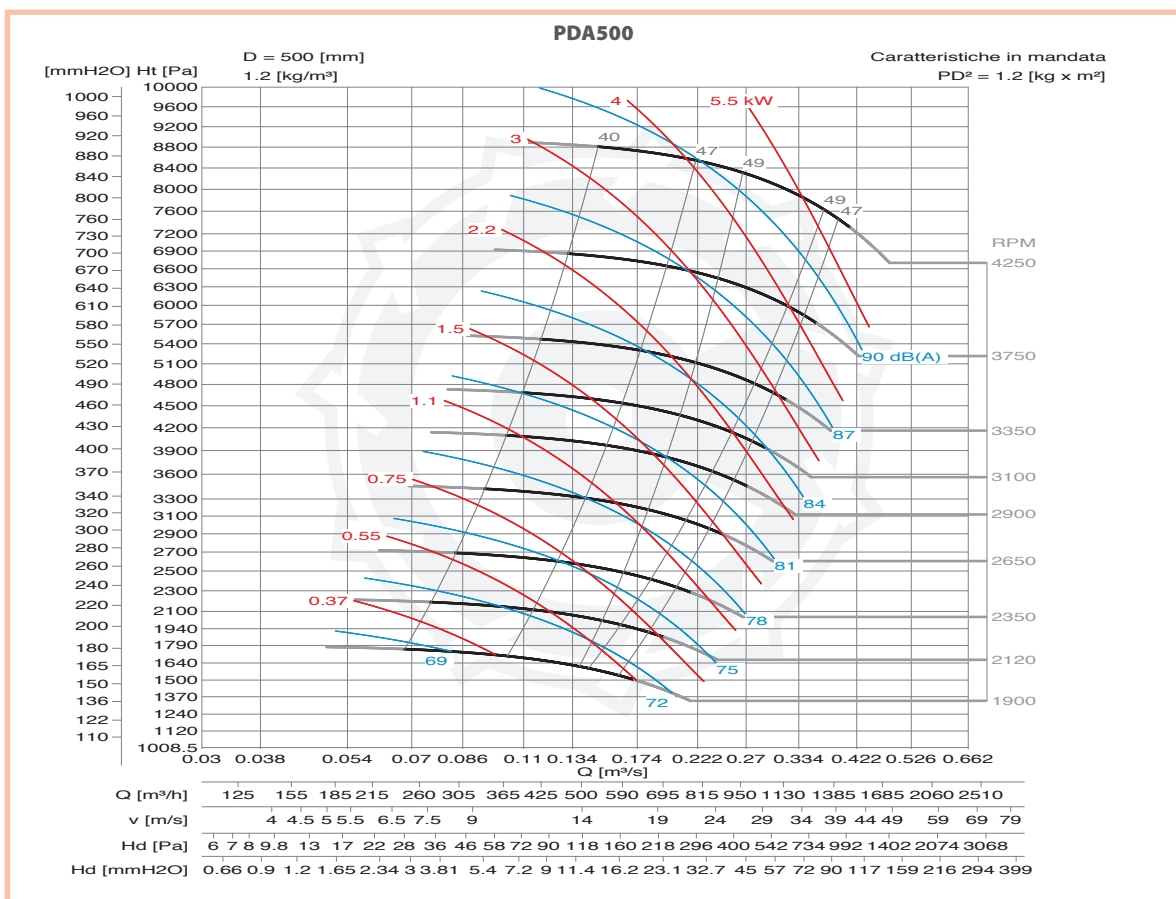
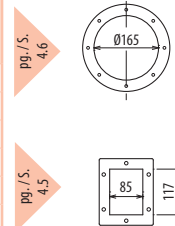

DIMENSIONI D'INGOMBRO E PESI/CURVE DI FUNZIONAMENTO

■ DIMENSIONS D'ENCOMBREMENT ET POIDS/COURBES DE FONCTIONNEMENT ■ OVERALL DIMENSIONS AND WEIGHT/WORKING CURVES
 ■ AUSMAßE UND GEWICHTE/FUNKTIONSKURVEN ■ DIMENSIONES QUE OCUPA Y PESOS/CURVAS DE FUNCIONAMIENTO

PDA560/P

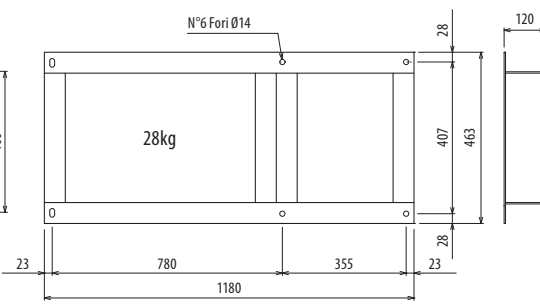
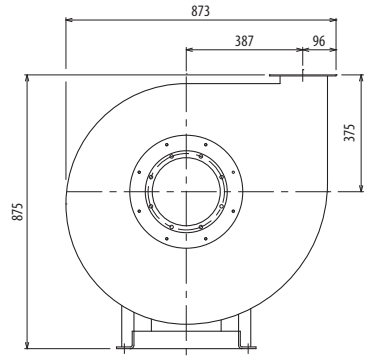
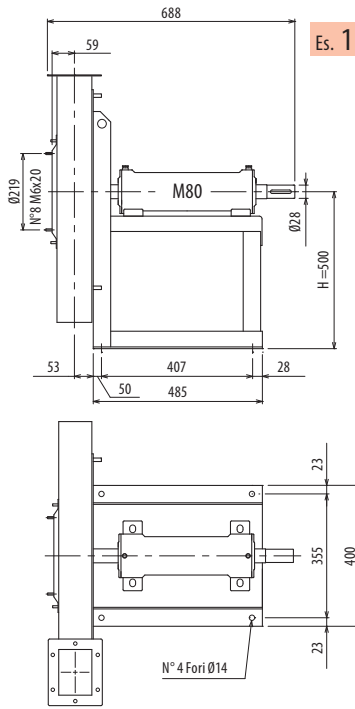
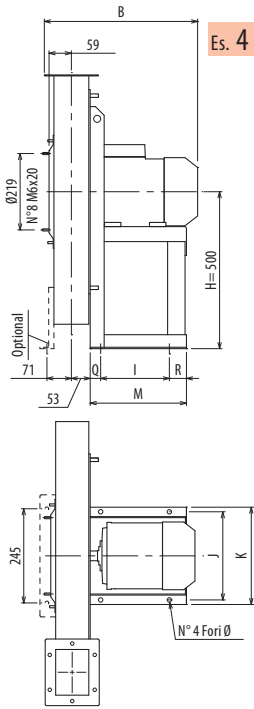

Il ventilatore è orientabile • Peso in tabella comprensivo di motore

- Le ventilateur est orientable ■ The fan is revolvable ■ Der Ventilator ist drehbar ■ El ventilador es orientable
- Le poids dans le tableau inclut le moteur The weight indicated in the table includes motor Das Gewicht in der Tafel schließt den Motor ein El peso en la tabla incluye el motor

Ulteriori informazioni e quote:
 ■ Ulérieures informations et cotes:
 Further information and sizes:
 ■ Weitere Infos und Größen:
 Más informaciones y medidas:

TIPO - Type		PESO Weight	PD ²	B	I	H	H1	H2	J	K	M	Q	R	Ø
VENTILATORE Fan	MOTORE Motor	Kg	Kgf x m ²											
PDA560/P2	100 L2	89	1,7	442	197	500	500*	500	289	324	276	30	49	12
PDA560/P2	112 M2	100	1,7	463	197	500	500*	500	289	324	276	30	49	12
PDA560/P/T		91	1,7			500	375	500						

pg. / s. 4,6
 pg. / s. 4,5

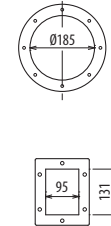

RD0 LG0

RD45 LG45

RD90 LG90

RD135 LG135

RD180 LG180

RD225 LG225

RD270 LG270

RD315 LG315

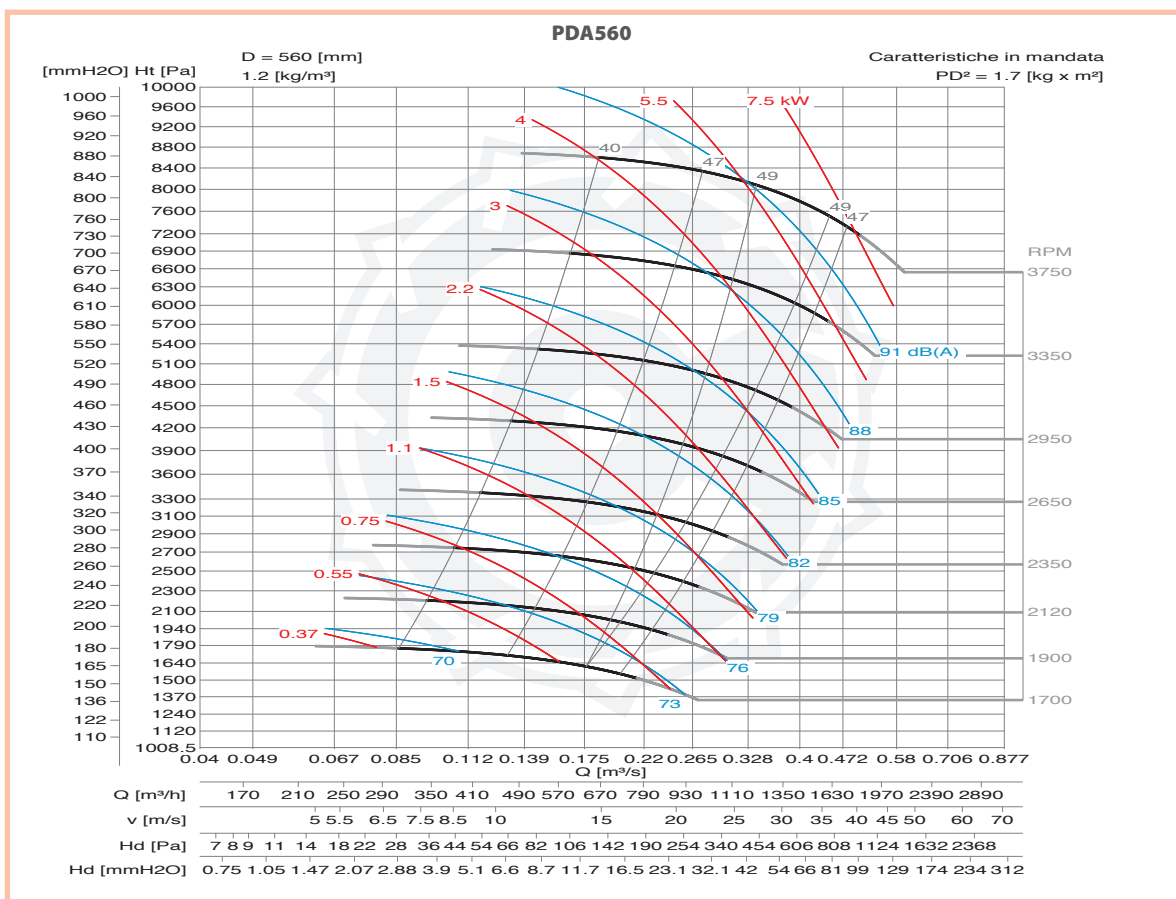

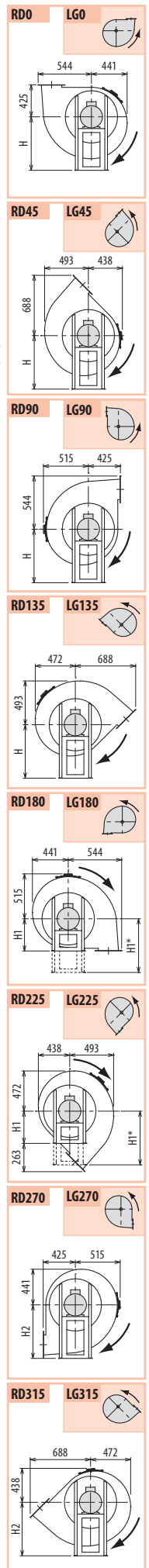
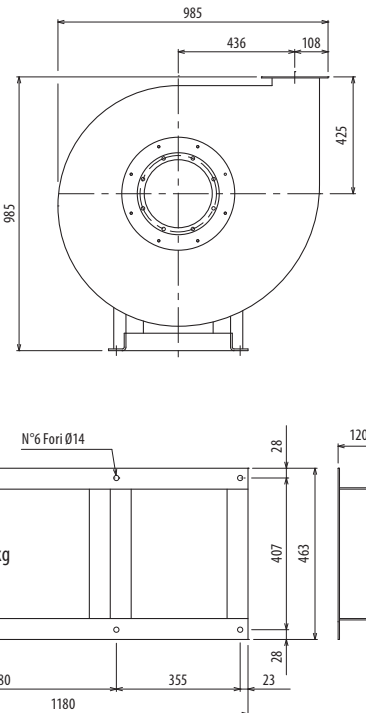
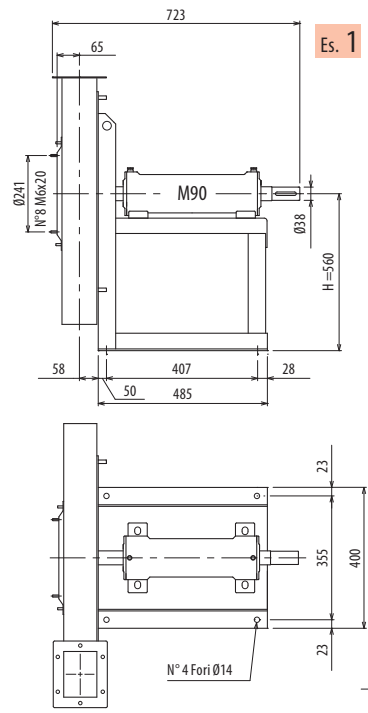
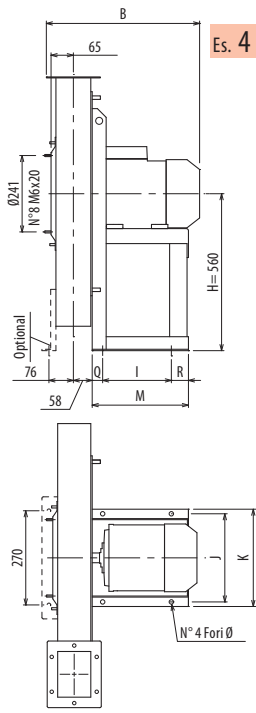

Il ventilatore è orientabile • Peso in tabella comprensivo di motore

- Le ventilateur est orientable ■ The fan is revolvable ■ Der Ventilator ist drehbar ■ El ventilador es orientable
- Le poids dans le tableau inclut le moteur The weight indicated in the table includes motor Das Gewicht in Tafel schließt den Motor ein El peso en la tabla incluye el motor

Ulteriori informazioni e quote:
■ Ulérieures informations et cotes:
■ Further information and sizes:
■ Weitere Infos und Größen:
■ Más informaciones y medidas:

TIPO - Type		PESO Weight	PD ²	B	I	H	H1	H2	J	K	M	Q	R	Ø
VENTILATORE Fan	MOTORE Motor	Kg	Kgf x m ²											
PDA630/P2	132 SA2	134	3,4	518	237	560	560*	560	337	372	336	40	59	12
PDA630/P2	132 SB2	134	3,4	518	237	560	560*	560	337	372	336	40	59	12
PDA630/P/T		118	3,4			560	425	560						

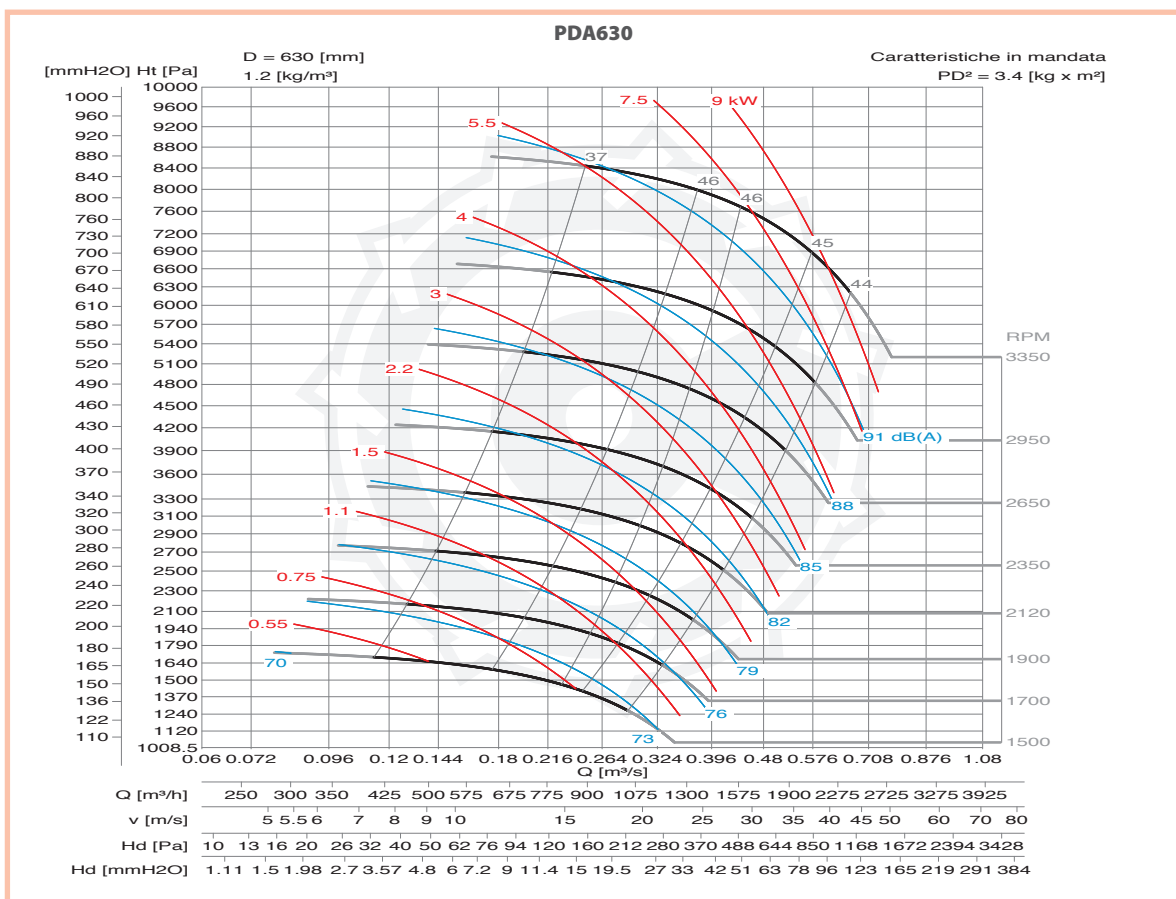
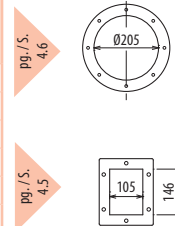

DIMENSIONI D'INGOMBRO E PESI/CURVE DI FUNZIONAMENTO

■ DIMENSIONS D'ENCOMBREMENT ET POIDS/COURBES DE FONCTIONNEMENT
 ■ OVERALL DIMENSIONS AND WEIGHT/WORKING CURVES
■ AUSMAßE UND GEWICHTE/FUNKTIONSKURVEN
 ■ DIMENSIONES QUE OCUPA Y PESOS/CURVAS DE FUNCIONAMIENTO

PDA710/P



ANTIPOLLUTION SYSTEMS

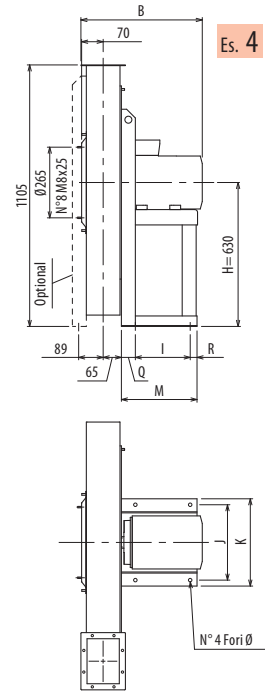

Es. 4

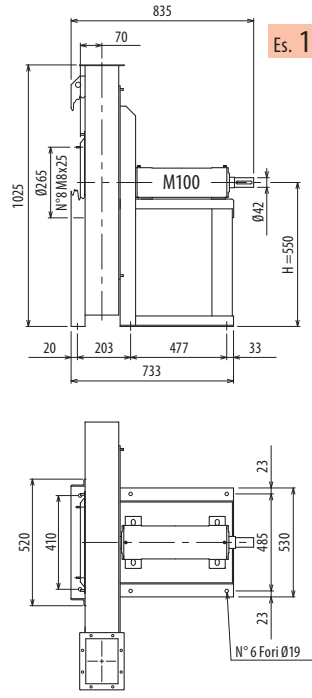

Es. 1

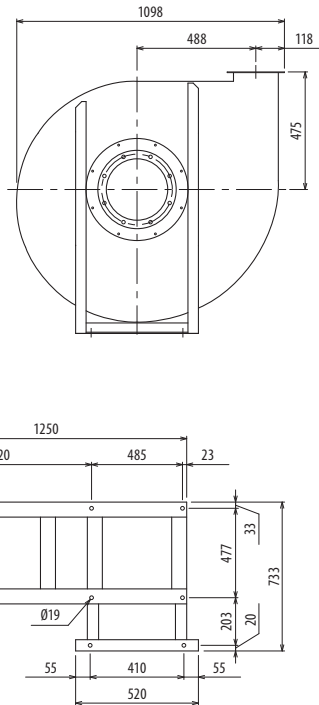

Il ventilatore in Es. 4 senza supporto anteriore è orientabile, in Es. 1 non è orientabile • Peso in tabella comprensivo di motore

- Le ventilateur en Ex. 4 sans support frontal est orientable, en Ex. 1 n'est pas orientable. ■ The fan in Ex. 4 without front support is revoluble, in Ex. 1 is not revoluble.
- Der Ventilator in Aus. 4, ohne Vorderhalterung, ist drehbar; in Aus. 1 ist nicht drehbar. ■ El ventilador en Ej. 4 sin soporte delantero es orientable, en Ej. 1 no es orientable.
- Das Gewicht im Tafel schließt den Motor ein. ■ El peso en la tabla incluye el motor

Ulteriori informazioni e quote:
■ Ulérieures informations et cotes:
■ Further information and sizes:
■ Weitere Infos und Größen:
■ Más informaciones y medidas:

TIPO - Type		PESO Weight	PD ²													
VENTILATORE Fan	MOTORE Motor	Kg	Kg f x m ²	B	I	H	H1	H2	J	K	M	Q	R	Ø		
PDA710/P2	132 SB2	202	5,5	531	237	630*	630*	630	337	372	336	40	59	12		
PDA710/P2	160 MA2	218	5,5	636	337	630*	630*	630	395	440	436	50	49	14		
PDA710/P/T		179	5,5			550	475	630								

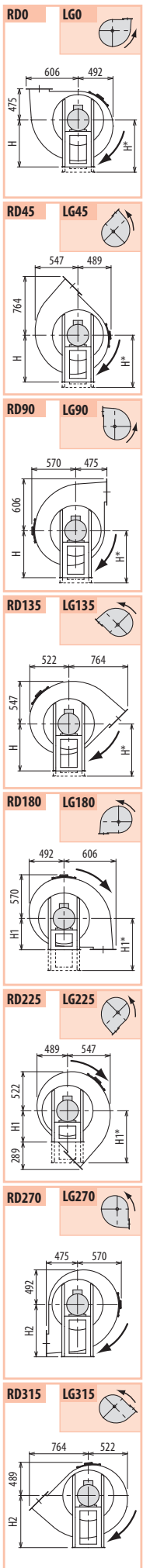
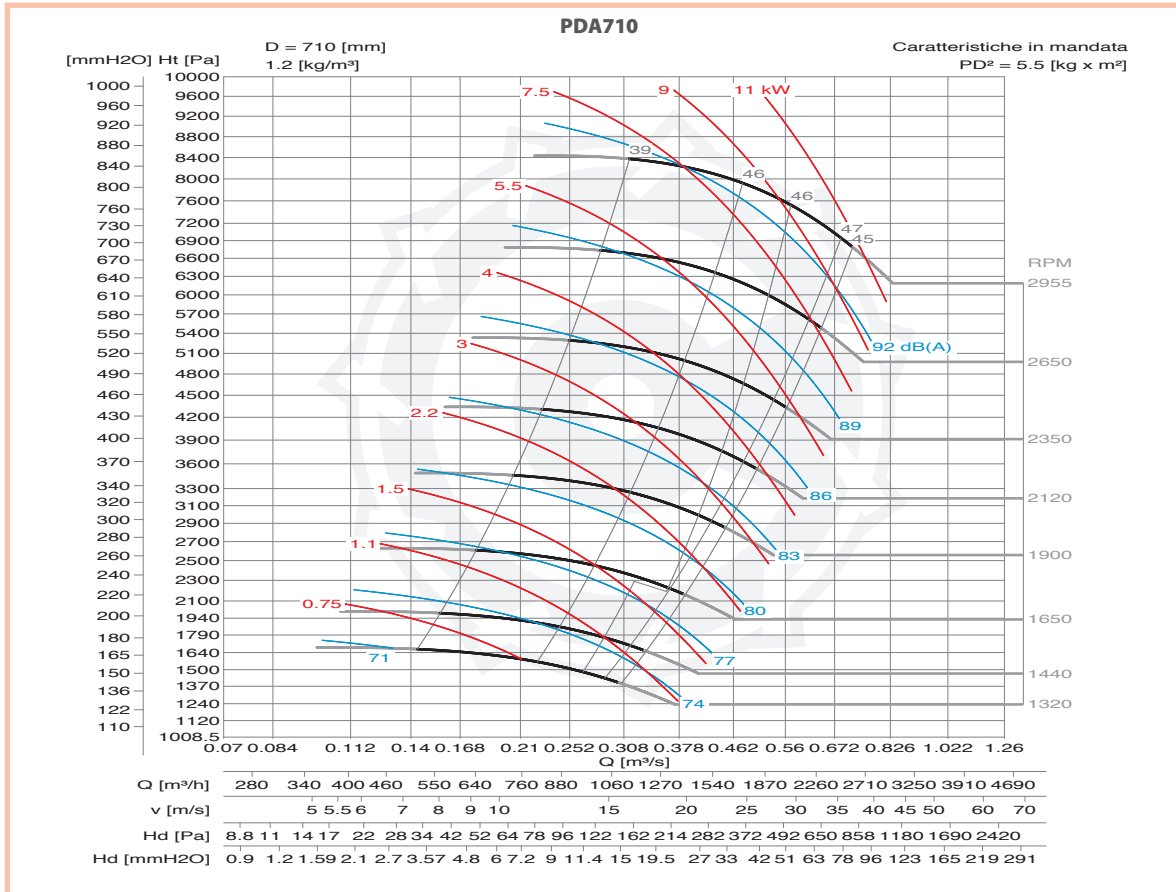
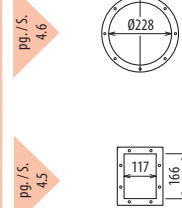

PDA

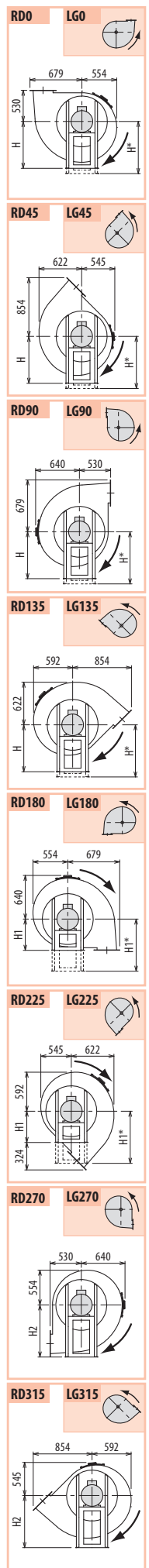
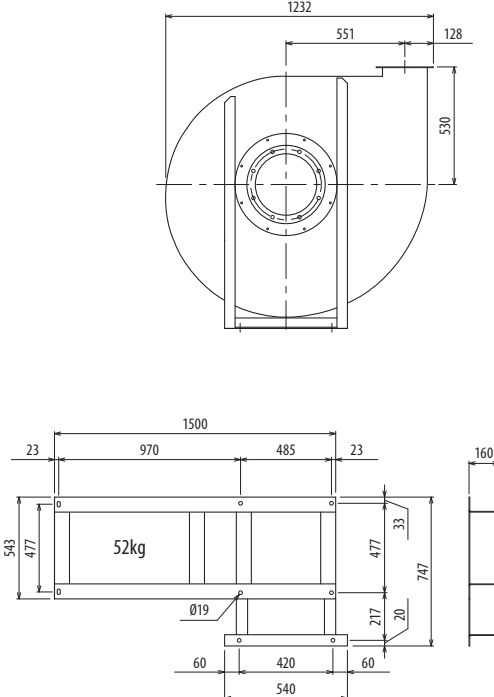
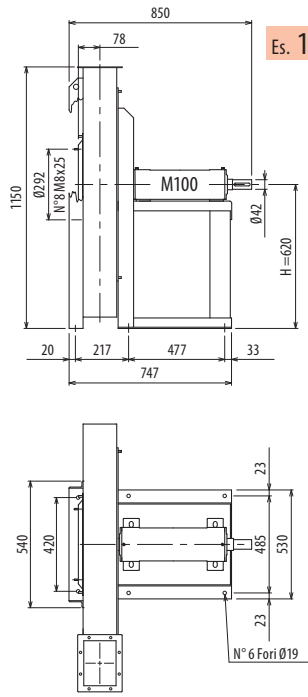
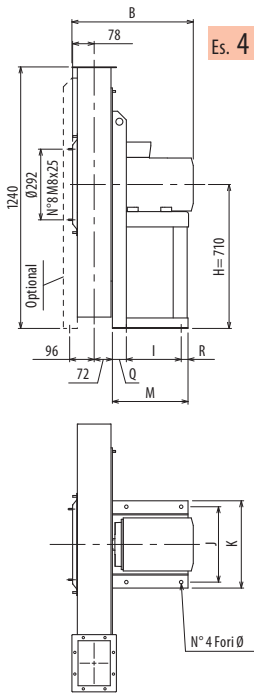

Il ventilatore in ES. 4 senza supporto anteriore è orientabile, in ES. 1 non è orientabile • Peso in tabella comprensivo di motore

- Le ventilateur en Ex. 4 sans support frontal est orientable, en Ex. 1 n'est pas orientable. Le poids dans le tableau inclut le moteur
- The fan in Ex. 4 without front support is revolvable, in Ex. 1 is not revolvable. The weight indicated in the table includes motor
- Der Ventilator in Aus. 4, ohne Vorderhalterung, ist drehbar; in Aus. 1 ist nicht drehbar.
- El ventilador en Ej. 4 sin soporte delantero es orientable, en Ej. 1 no es orientable. El peso en la tabla incluye el motor
- Más informaciones y medidas:

Ulteriori informazioni e quote:
■ Ulérieures informations et cotes:
■ Further information and sizes:
■ Weitere Infos und Größen:
■ Más informaciones y medidas:

TIPO - Type		PESO Weight	PD ²	B	I	H	H1	H2	J	K	M	Q	R	Ø
VENTILATORE Fan	MOTORE Motor	Kg	Kgf x m ²											
PDA800/P2R	160 MB2	262	9	650	337	710*	710*	710	395	440	436	50	49	14
PDA800/P2	160 L2	277	12	650	337	710*	710*	710	395	440	436	50	49	14
PDA800/P4R	100 LB4	195	9	484	197	710*	710*	710	289	324	276	30	49	12
PDA800/P4	112 M4	202	12	505	197	710*	710*	710	289	324	276	30	49	12
PDA800/P/T		217	12			620	530	710						

pg. / s. 4,6
pg. / s. 4,5

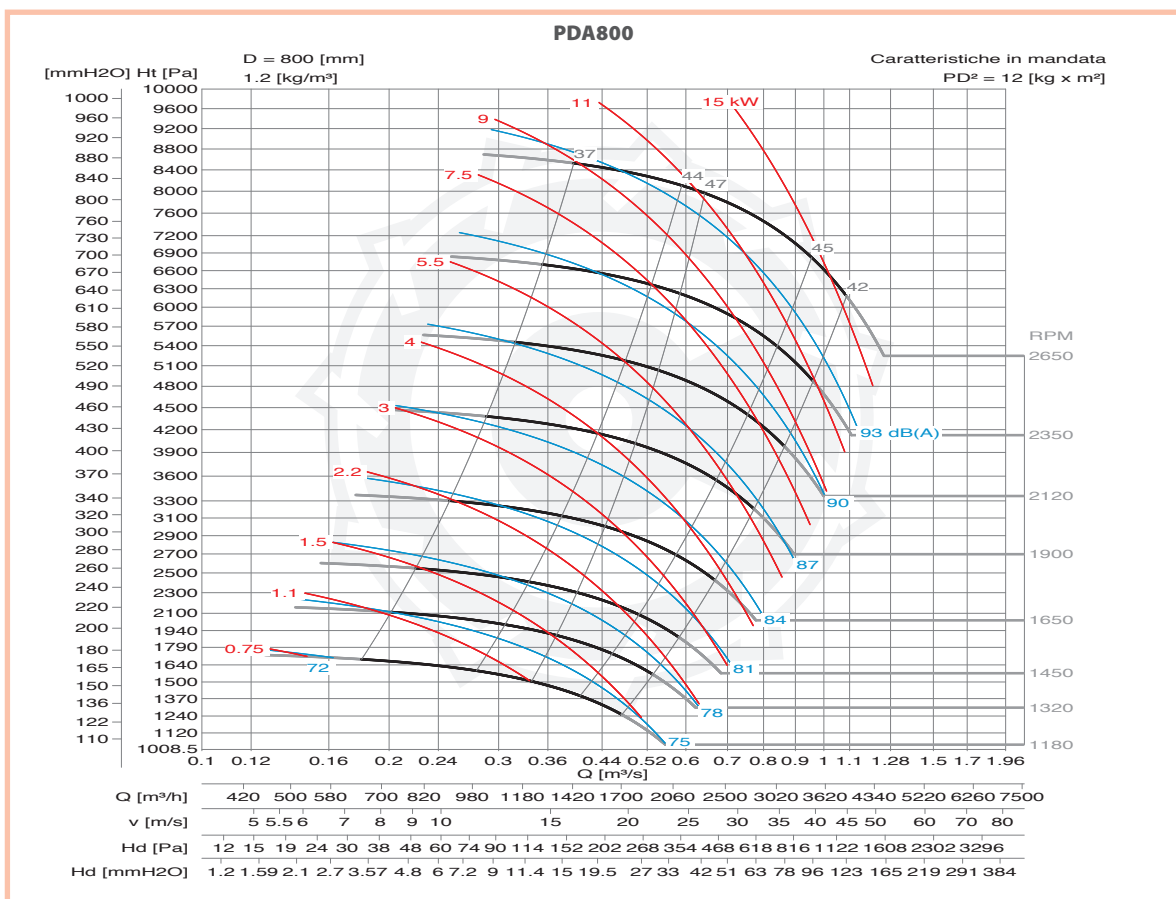
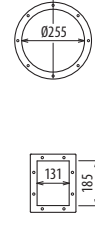

DIMENSIONI D'INGOMBRO E PESI/CURVE DI FUNZIONAMENTO

■ DIMENSIONS D'ENCOMBREMENT ET POIDS/COURBES DE FONCTIONNEMENT ■ OVERALL DIMENSIONS AND WEIGHT/WORKING CURVES
 ■ AUSMARE UND GEWICHTE/FUNKTIONSKURVEN ■ DIMENSIONES QUE OCUPA Y PESOS/CURVAS DE FUNCIONAMIENTO

PDA900/P

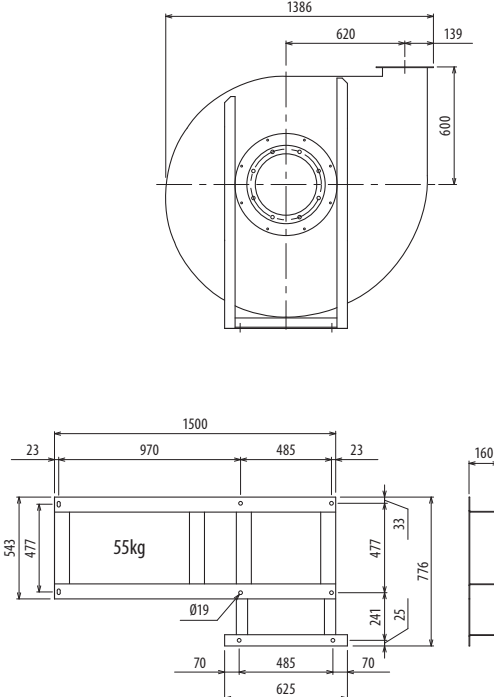
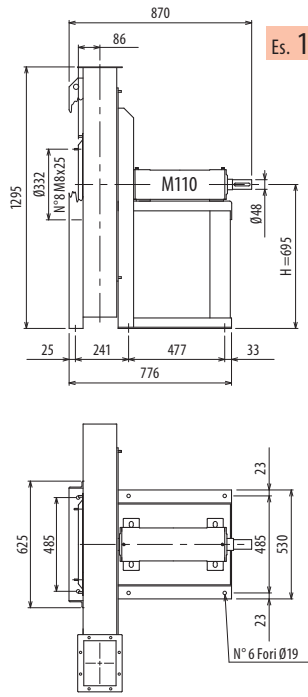
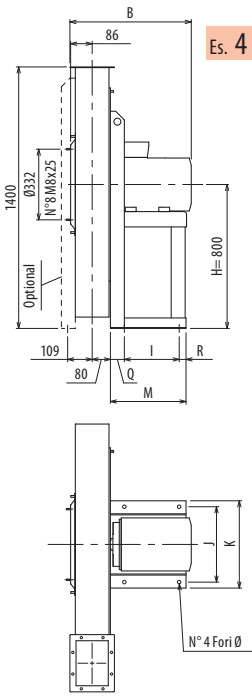

Il ventilatore in Es. 4 senza supporto anteriore è orientabile, in Es. 1 non è orientabile • Peso in tabella comprensivo di motore

- Le ventilateur en Ex. 4 sans support frontal est orientable, en Ex. 1 n'est pas orientable. Le poids dans le tableau inclut le moteur
- Der Ventilator in Aus. 4, ohne Vorderhalterung, ist drehbar; in Aus. 1 ist nicht drehbar. Das Gewicht in Tafel schließt den Motor ein
- The fan in Ex. 4 without front support is revolvable, in Ex. 1 is not revolvable. The weight indicated in the table includes motor
- El ventilador en Ej. 4 sin soporte delantero es orientable, en Ej. 1 no es orientable. El peso en la tabla incluye el motor

Ulteriori informazioni e quote:
 ■ Ulérieures informations et cotes:
 ■ Further information and sizes:
 ■ Weitere Infos und Größen:
 ■ Más informaciones y medidas:

TIPO - Type		PESO Weight	PD ²	B	I	H	H1	H2	J	K	M	Q	R	Ø
VENTILATORE Fan	MOTORE Motor	Kg	Kg x m ²											
PDA900/P4R	132 SA4	307	14	562	237	800*	800*	800	337	372	336	40	59	12
PDA900/P4	132 MA4	341	18	562	237	800*	800*	800	337	372	336	40	59	12
PDA900/P/T		280	18			695	600	800						

pg. / s. 4,6

pg. / s. 4,5

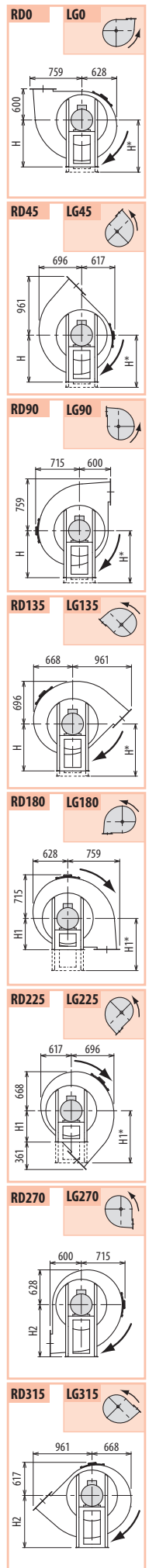

PDA

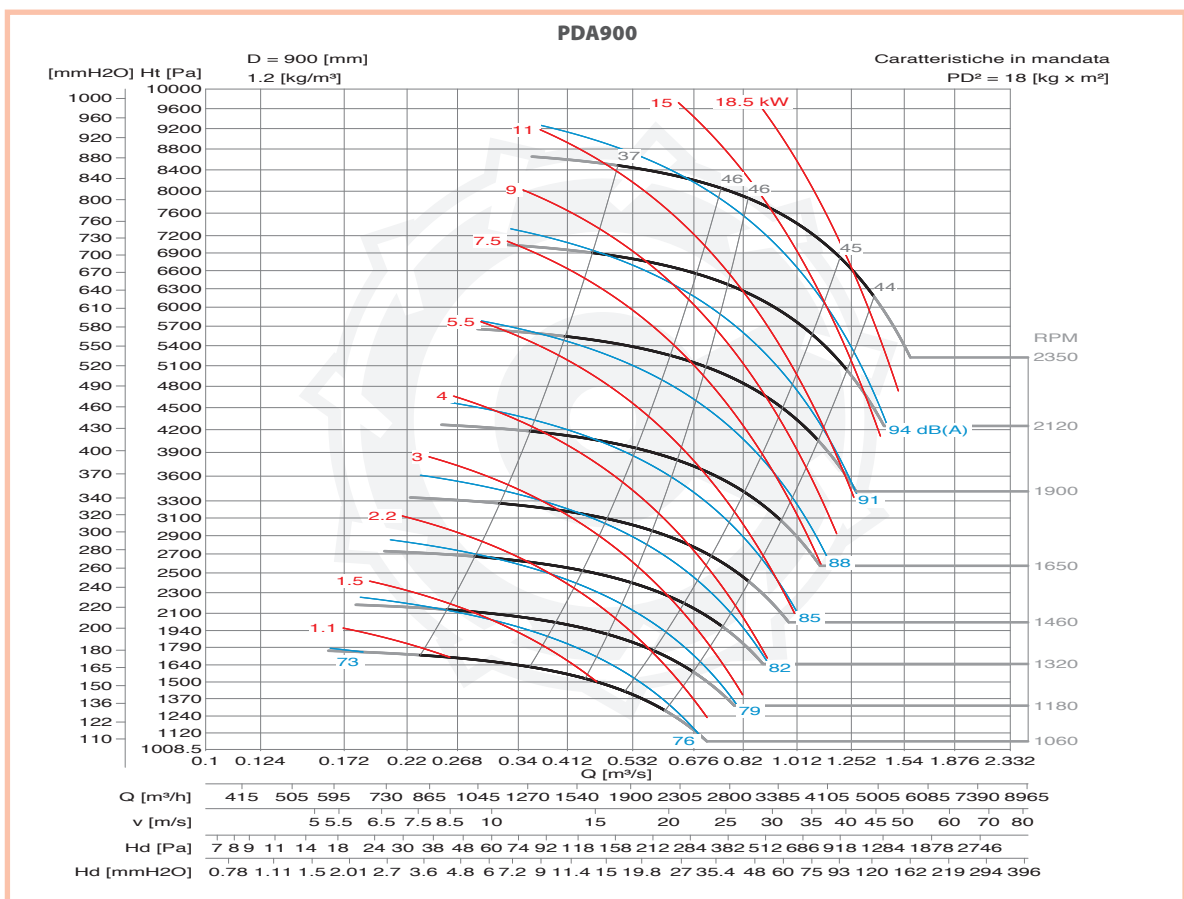

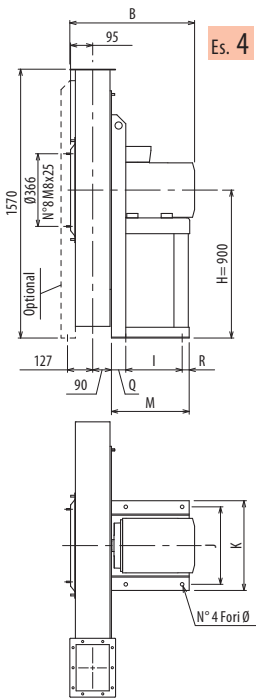

Es. 4

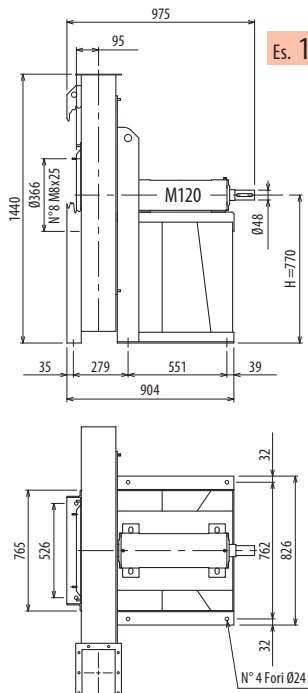

Es. 1

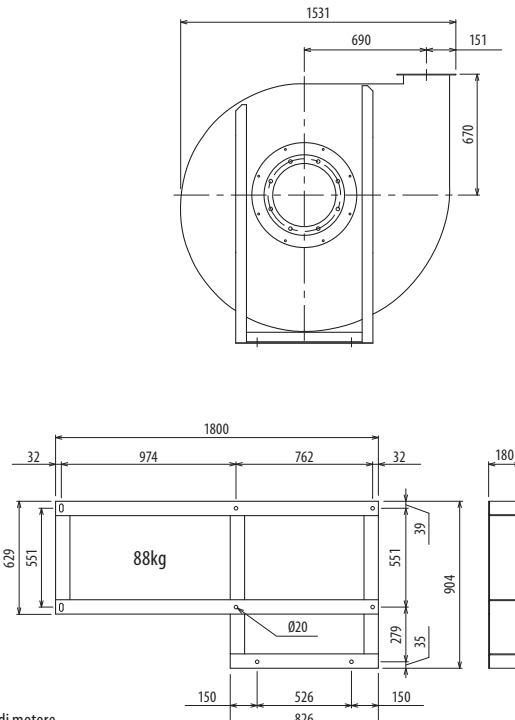

Il ventilatore in Es. 4 senza supporto anteriore è orientabile, in Es. 1 non è orientabile • Peso in tabella comprensivo di motore

- Le ventilateur in Ex. 4 sans support frontal est orientable, in Ex. 1 n'est pas orientable. Le poids dans le tableau inclut le moteur
- Der Ventilator in Aus. 4, ohne Vorderhalterung, ist drehbar; in Aus. 1 ist nicht drehbar. Das Gewicht in Tafel schließt den Motor ein
- The fan in Ex. 4 without front support is revolvable, in Ex. 1 is not revolvable. The weight indicated in the table includes motor
- El ventilador en Ej. 4 sin soporte delantero es orientable, en Ej. 1 no es orientable. El peso en la tabla incluye el motor

Ulteriori informazioni e quote:
■ Ulérieures informations et cotes:
■ Further information and sizes:
■ Weitere Infos und Größen:
■ Más informaciones y medidas:

TIPO - Type		PESO Weight	PD ²											
VENTILATORE Fan	MOTORE Motor	Kg	Kgf x m ²	B	I	H	H1	H2	J	K	M	Q	R	Ø
PDA1000/P4R	132 MA4	370	25	581	237	900*	900*	900	337	372	336	40	59	12
PDA1000/P4	160 M4	410	30	686	337	900*	900*	900	395	440	436	50	49	14
PDA1000/P/T		365	30			770	670	900						

pg. / s. 4.6



pg. / s. 4.5

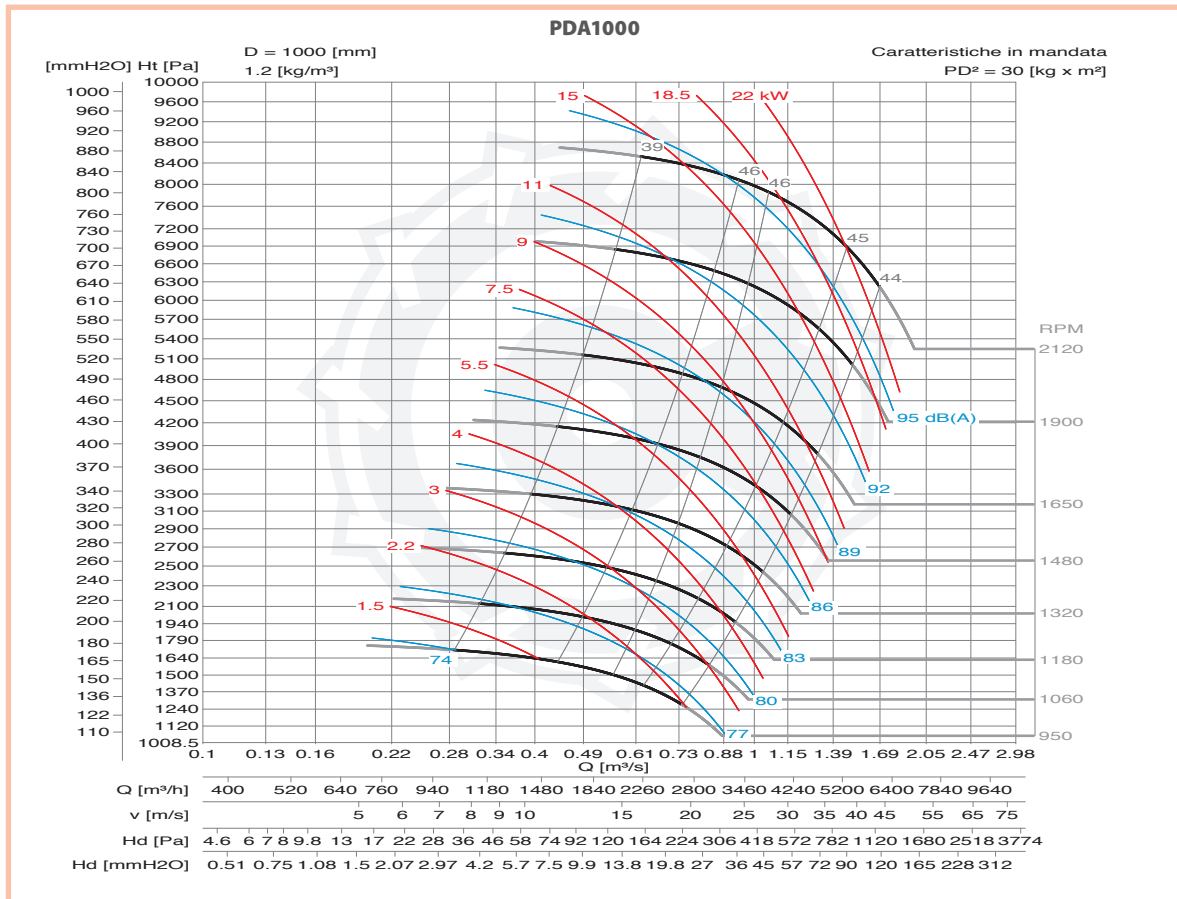
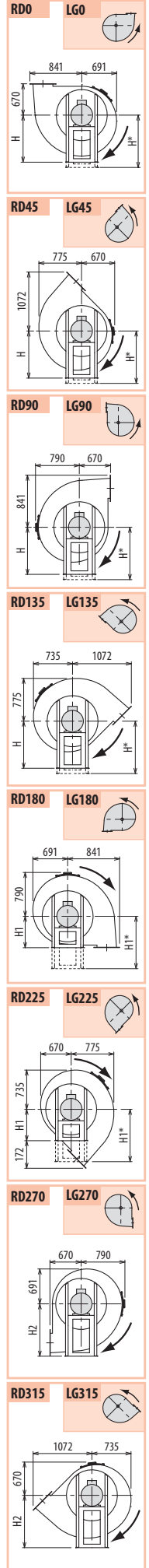



CORAL ENGINEERING SRL

Via Venezia 4/6 - 20060 Trezzano Rosa (MI) ITALY

• +39 02 95301003 - Fax +39 02 95301004

e-mail: info@coral.it <http://www.coral.it>

SOCIETÀ DI ENGINEERING - SOCIÉTÉS D'INGENIERIE - ENGINEERING SISTER COMPANIES - INGENIEURFIRMEN - SOCIEDADES DE INGENIERIA

ITALIA

MILANO • +39 02 95301003
TORINO • +39 011 9980141
VICENZA • +39 0444 348999

FRANCE

LYON • +33 4 74 944 562
PARIS • +33 1 60 868 069
POITIERS • +33 5 49 379 596

ENGLAND

LITTLEBOROUGH ROCHDALE • +44 1 706 373100